



The City of  
**OKLAHOMA CITY**  
Utilities Department  
Chris Browning, Director

Oklahoma City Policy Regarding the Rental of Lake Hefner and Lake Draper Wet and Dry Stalls

Pursuant to **City Ordinance 38-249 (b)**, the polices, adopted in 2010, are hereby reissued as amended:

I. An application form is hereby adopted, please see the attached forms. Any person wishing to lease either a wet or dry stall at a City Lake, must complete the application form. The application form must be filled out legibly. **City Ordinance 38-247 (c)**, requires that the permit application must include:

- A. A copy of the title, registration, state permit and city permit for the vessel;
- B. Photo identification of the applicant;
- C. Payment of all fees;
- D. Acknowledgement of the applicant indemnifying the City and the Water

Utilities Trust.

II. In accordance with **City Ordinance 38-248 (d)**, any person leasing a wet or dry stall shall keep the stall in a clean, wholesome, sanitary and sightly condition and shall not permit debris or prohibited items to be installed, placed on or accumulate in or about said stall, public boat docks, or dry storage area. For the purposes of this policy, the terms "clean, wholesome, sanitary and sightly condition" shall include:

A. The vessel stored in the stall (whether wet or dry) shall only store items inside the vessel that may be used while the vessel is in use;

B. The paint on the vessel stored in the stall (whether wet or dry) shall not be peeling, chipping, cracking or overly worn;

C. In accordance with **City Ordinance 38-248 (c)**, the vessel stored in the stall shall be covered and/or secured with marine materials manufactured for the purposes of securing or protecting a vessel. Such materials shall be free from tears, rips, cracks and are not overly worn;

D. The vessel stored in the stall shall not contain mold or bottom growth; or

E. The wet or dry boat stall and area around the vessel shall not contain refuge, trash, clutter or be a location where major repairs or work on the vessel occurs.

III. **City Ordinance 38-248 (e)**, requires that no permanent item be placed or stored in a wet stall, except a locker that meets the policy requirements of the Utilities Director. Attached is the policy adopted by the Utilities Director.

IV. **City Ordinance 38-247 (b)**, requires:

A. Only navigable vessels be docked in a wet stall or parked in a dry stall. For the purposes of this provision, for a vessel to be navigable, the vessel must:

1. Be watertight;
2. Not be deteriorating (no exposed wires, no ripped or torn interior, must have a way for the vessel to be steered); and
3. Have a way to be propelled;

B. Only operable trailers be stored in a dry stall;

1. For the purposes of this provision, for a trailer to be operable, the trailer must:

3. Not have any flat tires;
4. Have the ability to move; and
5. Be able to support the weight of the vessel(s);

C. Ownership of the vessel and/or trailer must be demonstrated before a wet or dry stall is leased and stall can only be leased to the person whose name appears on the title or registration for the vessel or trailer; and

D. Proof that a city boat permit was issued for the vessel to be stored in a wet or dry stall, before the wet or dry stall can be leased.

V. **City Ordinances 38-247 (b) and 38-246 (e)**, allows for only one vessel or trailer to be stored in either a wet or dry stall. A trailer that is constructed by the manufacturer to store more than one vessel (examples include a trailer that houses two sea doos or can house more than one kayak or canoe) are allowed.

VI. **City Ordinance 38-245 (a)** requires that all vessels and trailers shall be completely stored within the rented stall. Any vessel, trailer or personal property not completely contained within the rented stall shall be subject to removal. For dry stalls, the stall dividers shall not be moved.

VII. **City Ordinance 38-211 (a)** prohibits the hunting, shooting, capturing or killing of any animals on City Lakes, including the wet and dry stalls, located at Lake Hefner and Lake Stanley Draper.

VIII. **City Ordinance 38-246 (d)** prohibits the assignment or subleasing of a wet or dry stall, except pursuant to a policy adopted by the Utilities Director. If the vessel identified in a wet or dry stall lease is sold by the current lessee, the wet or dry stall may be assigned to the new owner of the vessel, provided:

- A. The new owner completes the attached application form;
- B. Provides all the information required by **City Ordinance 38-247 (c)**, as identified above; and
- C. The vessel and/or trailer meet the requirements of this policy.

Originally issued on September 1, 2010

Modified on January 16, 2020

  
Utilities Director

1-17-2020  
Date

**HEFNER - WET/DRY STALL RENTAL PERMIT**

No. H00001

New Rental       Change \_\_\_\_\_

Annual Rental: Auto-Renews Annually on \_\_\_\_\_       \*\*Short-Term Rental: Effective Date \_\_\_\_\_ Expires \_\_\_\_\_

Owner \_\_\_\_\_

\*Please provide an additional contact person for emergency notifications.

Mailing Address \_\_\_\_\_

\*Additional Contact \_\_\_\_\_

City, State, Zip \_\_\_\_\_

Primary Phone \_\_\_\_\_ Secondary Phone \_\_\_\_\_

Primary Phone \_\_\_\_\_ Secondary Phone \_\_\_\_\_

Circle one:      H-home; C-call; W-work      H-home; C-call; W-work

Circle one:      H-home; C-call; W-work      H-home; C-call; W-work

E-mail: \_\_\_\_\_

E-Mail: \_\_\_\_\_

I affirm that I have a valid City boat permit. I understand I must notify the Director of changes to any information listed below within 30 days of such change. \_\_\_\_\_ (Initial)

Wet/Dry	Size	Stall No.	State No.	Type	Brand	Length	Color	No. Mos. & Days	Amount
									\$
									\$
									\$
									\$

OKC Boat Permit Expiration Date \_\_\_\_\_

ADMINISTRATIVE FEE: \$ \_\_\_\_\_

TOTAL AMOUNT DUE: \$ \_\_\_\_\_

Combination(s): Dry: \_\_\_\_\_ East  West  Wet: Gate: \_\_\_\_\_

Total payment – will be billed to your next utility bill and must be paid in full. \*\*Short-term rentals must be paid at the marina.

Monthly payments (only for annual rentals) – Annual rental fee will be billed in equal payments of \$ \_\_\_\_\_ over the twelve-month rental period. I authorize The City of Oklahoma City to bill me in twelve equal monthly payments. I agree to the terms and conditions of authorization. I UNDERSTAND THAT SHOULD I TERMINATE MY UTILITY BILL ACCOUNT WITH THE CITY OF OKLAHOMA CITY OR VACATE THE STALL RENTED TO ME, THAT I WILL OWE THE ENTIRE BALANCE OF THE RENTAL FEE AND AUTHORIZE THE CITY TO BILL ME FOR THE BALANCE DUE. \_\_\_\_\_ (INITIAL)

**If you would like to sign up for automatic bank draft please go to [okc.gov](http://okc.gov) and click "Pay Your Utility Bill".**

Signature \_\_\_\_\_ Issued By \_\_\_\_\_ Date \_\_\_\_\_

Utilities Administration (white)      Marina (pink)      Customer (yellow)

Revised 07/2019

Name \_\_\_\_\_

**TERMS AND CONDITIONS**

This rental permit does not create a property right in the permittee, owner or other person. The City of Oklahoma City ("Oklahoma City") reserves the right to revoke this rental permit in its sole discretion for cause or without cause at any time during the permit period. Violation of any of these provisions or Oklahoma City ordinances or policies by permittee or his/her agent, guest or invitee shall be cause for immediate revocation of this rental permit by Oklahoma City. I agree, in the event this rental permit is revoked, the rental permit fee will not be refunded and I will, at my own expense, remove the boat, boat trailer, and/or any other personal property within ten calendar days. Upon expiration of this permit, my boat, trailer and other personal property may be removed or impounded at my expense by Oklahoma City or a wrecker service at any time. I agree to pay and/or reimburse Oklahoma City for any cost incurred by the removal, storage and/or disposal of my boat, boat trailer and/or personal property moved or removed from wet or dry stall pursuant to state law, Oklahoma City ordinances and/or policies. I agree to pay and/or reimburse Oklahoma City for any damage to the stall(s), public boat docks, and/or dry storage areas caused by me, by my boat, trailer and/or vehicle, and/or by my agents, guests and/or invitees. I acknowledge and understand that neither Oklahoma City nor the Oklahoma City Water Utilities Trust guarantees the water level in any City-operated reservoir. I understand and agree to the terms and conditions below.

1. In consideration of the issuance of this rental permit, I do hereby release, indemnify and hold harmless The City of Oklahoma City and the Oklahoma City Water Utilities Trust ("OCWUT") from any liability for any personal injury incurred by me and from any loss or damage incurred by me or any co-owner of any boat, boat trailer and/or other personal property on the City-operated reservoir, incurred as a direct or indirect result of theft, change in water level, act of nature, act of God, weather or act of a third person, removal or impoundment by Oklahoma City, otherwise, while using or occupying a stall, the public boat docks, the dry storage areas and/or a City-operated reservoir.
2. Permittee is responsible and legally liable for all persons, who the permittee allows to use or have access to the assigned stall and/or his/her boat. Permittee is responsible and liable for properly securing his/her boat, boat trailer and personal property in accordance with Oklahoma City ordinances and policies and the best practices for same.
3. NO REBATE of the stall rental permit fees will be made.
4. Permittee must timely pay and remain current on all Oklahoma City utility bills (water, wastewater and trash collection) and any other City account(s) jointly or individually, in the Permittee's name. In addition, if Permittee becomes delinquent in payment of rental permit fees, past due interest, or return check fees, it may result in termination of this Rental Permit and eviction proceedings may be initiated.
5. The boat registration and Oklahoma City boat permit for the boat assigned to the stall must be current and must remain current throughout rental period.
6. Permittee shall maintain the stall and the area surrounding the stall in a clean, wholesome, sanitary and dignified condition.
7. The stall shall be occupied ONLY by the boat(s) and/or trailer listed on this rental permit. Neither this rental permit nor the stall for which it is issued may be assigned or sublet by the permittee. Provided however, the Director may, upon his written approval, transfer the stall in accordance with Oklahoma City ordinances and policies. I agree not to attempt to assign, sublet, or transfer this rental permit or the stall to another, either temporarily or otherwise, without the prior written consent of the Director.
8. This permit will be auto-renewed annually. The permittee may, in accordance with Oklahoma City ordinances and policies, be issued the same stall for the next rental permit period. Permittee must contact Utilities Customer Service at (405) 297-2833 to cancel this rental permit at least 30 days prior to the expiration of this permit.
9. All rental permits expire and all stalls must be vacated on the last day of the rental permit if not renewed. Permittee agrees to restore the stall upon the expiration or revocation of this rental permit to the same (or better) condition as existed at the commencement of this rental permit, ordinary wear and tear excepted. Furthermore, permittee shall not build, place, erect, or install any structure or do any work of any kind at the stall, public boat docks or dry storage areas except as expressly authorized by the ordinances and policies of Oklahoma City. Except as otherwise provided in writing, all authorized improvements shall become the property of Oklahoma City upon acceptance.
10. Oklahoma City has the right to relocate boats and/or boat trailers to another stall, wet or dry, at any time it deems it necessary or in the best interest of Oklahoma City and the operation of the public boat docks and dry storage areas.
11. Oklahoma City shall have the right to move, remove and/or dispose of any boat, boat trailer and/or personal property (personal property) in or remaining in a stall with an expired or revoked rental permit, expired boat registration, expired Oklahoma City boat permit or not in compliance with the rental permit or Oklahoma City ordinances or policies. Oklahoma City shall have the right to take possession of any such personal property and dispose of it to satisfy any unpaid fees or charges in accordance with applicable law.

Signature \_\_\_\_\_

Date \_\_\_\_\_

**OFFICE USE ONLY**

Sent To / Date Sent

Logged / Date Logged

Premise

**DRAPER - WET/DRY STALL RENTAL PERMIT**

No. D00001

New Rental       Change \_\_\_\_\_

Annual Rental: Auto-Renews Annually on \_\_\_\_\_       \*\*Short-Term Rental: Effective Date \_\_\_\_\_ Expires \_\_\_\_\_

Owner \_\_\_\_\_

\*Please provide an additional contact person for emergency notifications.

Mailing Address \_\_\_\_\_

\*Additional Contact \_\_\_\_\_

City, State, Zip \_\_\_\_\_

Primary Phone \_\_\_\_\_ Secondary Phone \_\_\_\_\_

Primary Phone \_\_\_\_\_ Secondary Phone \_\_\_\_\_

Circle one:      H-home; C-call; W-work      H-home; C-call; W-work

Circle one:      H-home; C-call; W-work      H-home; C-call; W-work

E-mail: \_\_\_\_\_

E-Mail: \_\_\_\_\_

I affirm that I have a valid City boat permit. I understand I must notify the Director of changes to any information listed below within 30 days of such change. \_\_\_\_\_ (Initial)

Wet/Dry	Size	Stall No.	State No.	Type	Brand	Length	Color	No. Mos. & Days	Amount
									\$
									\$
									\$
									\$

OKC Boat Permit Expiration Date: \_\_\_\_\_

ADMINISTRATIVE FEE: \$  
TOTAL AMOUNT DUE: \$

Combination(s): Dry: \_\_\_\_\_ East  West  Wet: Gate: \_\_\_\_\_

Total payment – will be billed to your next utility bill and must be paid in full. \*\*Short-term rentals must be paid at the marina.

Monthly payments (only for annual rentals) – Annual rental fee will be billed in equal payments of \$\_\_\_\_\_ over the twelve-month rental period. I authorize The City of Oklahoma City to bill me in twelve equal monthly payments. I agree to the terms and conditions of authorization. I UNDERSTAND THAT SHOULD I TERMINATE MY UTILITY BILL ACCOUNT WITH THE CITY OF OKLAHOMA CITY OR VACATE THE STALL RENTED TO ME, THAT I WILL OWE THE ENTIRE BALANCE OF THE RENTAL FEE AND AUTHORIZE THE CITY TO BILL ME FOR THE BALANCE DUE. \_\_\_\_\_ (INITIAL)

**If you would like to sign up for automatic bank draft please go to [okc.gov](http://okc.gov) and click "Pay Your Utility Bill".**

Signature \_\_\_\_\_ Issued By \_\_\_\_\_ Date \_\_\_\_\_

Utilities Administration (white)      Marina (pink)      Customer (yellow)

Revised 07/2019

Name: \_\_\_\_\_

**TERMS AND CONDITIONS**

This rental permit does not create a property right in the permittee, owner or other person. The City of Oklahoma City ("Oklahoma City") reserves the right to revoke this rental permit in its sole discretion for cause or without cause at any time during the permit period. Violation of any of these provisions or Oklahoma City ordinances or policies by permittee or his/her agent, guest or invitee shall be cause for immediate revocation of this rental permit by Oklahoma City. I agree, in the event this rental permit is revoked, the rental permit fee will not be refunded and I will, at my own expense, remove the boat, boat trailer, and/or any other personal property within ten calendar days. Upon expiration of this permit, my boat, trailer and other personal property may be removed or impounded at my expense by Oklahoma City or a wrecker service at any time. I agree to pay and/or reimburse Oklahoma City for any cost incurred by the removal, storage and/or disposal of my boat, boat trailer and/or personal property moved or removed from wet or dry stall pursuant to state law, Oklahoma City ordinances and/or policies. I agree to pay and/or reimburse Oklahoma City for any damage to the stall(s), public boat docks, and/or dry storage areas caused by me, by my boat, trailer and/or vehicle, and/or by my agents, guests and/or invitees. I acknowledge and understand that neither Oklahoma City nor the Oklahoma City Water Utilities Trust guarantees the water level in any City-operated reservoir. I understand and agree to the terms and conditions below.

1. In consideration of the issuance of this rental permit, I do hereby release, indemnify and hold harmless The City of Oklahoma City and the Oklahoma City Water Utilities Trust ("OCWUT") from any liability for any personal injury incurred by me and from any loss or damage incurred by me or any co-owner of any boat, boat trailer and/or other personal property on the City-operated reservoir, incurred as a direct or indirect result of theft, change in water level, act of nature, act of God, weather or act of a third person, removal or impoundment by Oklahoma City, otherwise, while using or occupying a stall, the public boat docks, the dry storage areas and/or a City-operated reservoir.
2. Permittee is responsible and legally liable for all persons, who the permittee allows to use or have access to the assigned stall and/or his/her boat. Permittee is responsible and liable for properly securing his/her boat, boat trailer and personal property in accordance with Oklahoma City ordinances and policies and the best practices for same.
3. NO REBATE of the stall rental permit fees will be made.
4. Permittee must timely pay and remain current on all Oklahoma City utility bills (water, wastewater and trash collection) and any other City account(s) jointly or individually, in the Permittee's name. In addition, if Permittee becomes delinquent in payment of rental permit fees, past due interest, or return check fees, it may result in termination of this Rental Permit and eviction proceedings may be initiated.
5. The boat registration and Oklahoma City boat permit for the boat assigned to the stall must be current and must remain current throughout rental period.
6. Permittee shall maintain the stall and the area surrounding the stall in a clean, wholesome, sanitary and dignified condition.
7. The stall shall be occupied ONLY by the boat(s) and/or trailer listed on this rental permit. Neither this rental permit nor the stall for which it is issued may be assigned or sublet by the permittee. Provided however, the Director may, upon his written approval, transfer the stall in accordance with Oklahoma City ordinances and policies. I agree not to attempt to assign, sublet, or transfer this rental permit or the stall to another, either temporarily or otherwise, without the prior written consent of the Director.
8. This permit will be auto-renewed annually. The permittee may, in accordance with Oklahoma City ordinances and policies, be issued the same stall for the next rental permit period. Permittee must contact Utilities Customer Service at (405) 297-2833 to cancel this rental permit at least 30 days prior to the expiration of the permit.
9. All rental permits expire and all stalls must be vacated on the last day of the rental permit if not renewed. Permittee agrees to restore the stall upon the expiration or revocation of this rental permit to the same (or better) condition as existed at the commencement of this rental permit, ordinary wear and tear excepted. Furthermore, permittee shall not build, place, erect, or install any structure or do any work of any kind at the stall, public boat docks or dry storage areas except as expressly authorized by the ordinances and policies of Oklahoma City. Except as otherwise provided in writing, all authorized improvements shall become the property of Oklahoma City upon acceptance.
10. Oklahoma City has the right to relocate boats and/or boat trailers to another stall, wet or dry, at any time it deems it necessary or in the best interest of Oklahoma City and the operation of the public boat docks and dry storage areas.
11. Oklahoma City shall have the right to move, remove and/or dispose of any boat, boat trailer and/or personal property (personal property) in or remaining in a stall with an expired or revoked rental permit, expired boat registration, expired Oklahoma City boat permit or not in compliance with this rental permit or Oklahoma City ordinances or policies. Oklahoma City shall have the right to take possession of any such personal property and dispose of it to satisfy any unpaid fees or charges in accordance with applicable law.

Signature \_\_\_\_\_ Date \_\_\_\_\_

OFFICE USE ONLY			
Sent To / Date Sent	<input type="text"/>	<input type="text"/>	<input type="text"/>
Logged / Date Logged	<input type="text"/>	<input type="text"/>	<input type="text"/>
Premise	<input type="text"/>	<input type="text"/>	<input type="text"/>

## DOCK BOX POLICY

Sec. 38-248(e)(1). No item may be permanently placed on or in the wet stall except one locker of the size and construction state in the policy for lockers as established by the Director. Such locker may only be secured as provided by the Director in said policy.

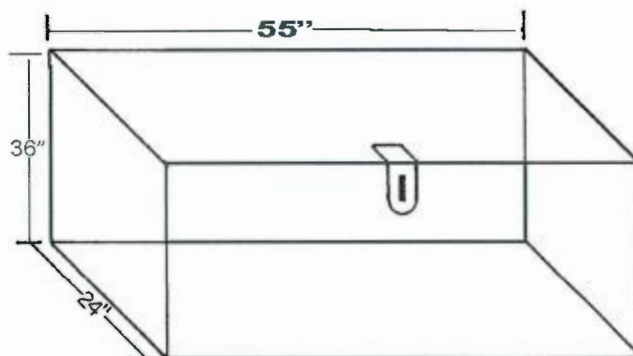

APPROVED MAXIMUM DIMENSIONS: 36" H x 24" W x 55" L

APPROVED MATERIALS :

Preformed Plastic, Rubber,  
Metal or Wood\*

APPROVED PAINTS/COLORS:

Dark shades of gray, blue, green or brown,  
Black or natural wood finish

APPROVED INSTALLATION  
AND LOCATION:

May be strapped to an available support beam  
or railing as long as it does not create a safety  
or walkway hazard; permittee must have  
written approval of the General Manager or his  
designee to attach the box to the structure.

\*Docks may be periodically cleaned with a power washer. Dock boxes should therefore be weatherproof and be able to withstand sprayed water. Wood boxes should be coated with water repellent.