

QUANTITIES		SECTION DIMENSIONS						REINFORCING STEEL																																	
PER FOOT OF BARREL								A1 BARS			A2 BARS			B1 BARS			B2 BARS			C1 BARS			C2 BARS			E1 BARS AT 12" MAX.			E2 BARS AT 12" MAX.												
CONC. (C.Y.)	REINF. (LB.)	S	H	T	U	W	Z	SIZE	SPA.	LENGTH	WEIGHT PER FT.	SIZE	SPA.	LENGTH	WEIGHT PER FT.	SIZE	SPA.	"X" (HORIZ.)	"Y" (VERT.)	LENGTH	WEIGHT PER FT.	SIZE	SPA.	"X" (HORIZ.)	"Y" (VERT.)	LENGTH	WEIGHT PER FT.	SIZE	SPA.	LENGTH	WEIGHT PER FT.	NO.	SIZE	WEIGHT PER FT.	NO.	SIZE	WEIGHT PER FT.				
1.36	173.1	4'	3'	10"	11"	10"	10"	#5	12"	15'-0"	31.3	#4	6"	15'-0"	40.1	#5	12"	2'-8"	2'-8"	5'-4"	11.1	#5	12"	2'-8"	3'-8"	6'-4"	13.2	#4	12"	2'-3"	3.0	#4	12"	3'-8"	4.9	80	#4	53.4	24	#4	16.0
1.49	181.8	4'	4'	10"	11"	10"	10"	#5	12"	15'-0"	31.3	#4	6"	15'-0"	40.1	#5	12"	2'-8"	2'-8"	5'-4"	11.1	#5	12"	2'-8"	4'-8"	7'-4"	15.3	#4	12"	2'-3"	3.0	#4	12"	4'-8"	6.2	80	#4	53.4	32	#4	21.4
1.56	195.4	5'	3'	10"	11"	10"	10"	#5	12"	18'-0"	37.5	#4	6"	18'-0"	48.1	#5	12"	2'-8"	2'-8"	5'-4"	11.1	#5	12"	2'-8"	3'-8"	6'-4"	13.2	#4	12"	2'-3"	3.0	#4	12"	3'-8"	4.9	92	#4	61.5	24	#4	16.0
1.68	204.1	5'	4'	10"	11"	10"	10"	#5	12"	18'-0"	37.5	#4	6"	18'-0"	48.1	#5	12"	2'-8"	2'-8"	5'-4"	11.1	#5	12"	2'-8"	4'-8"	7'-4"	15.3	#4	12"	2'-3"	3.0	#4	12"	4'-8"	6.2	92	#4	61.5	32	#4	21.4
1.81	212.9	5'	5'	10"	11"	10"	10"	#5	12"	18'-0"	37.5	#4	6"	18'-0"	48.1	#5	12"	2'-8"	2'-8"	5'-4"	11.1	#5	12"	2'-8"	5'-8"	8'-4"	17.4	#4	12"	2'-3"	3.0	#4	12"	5'-8"	7.6	92	#4	61.5	40	#4	26.7

NOTE:
A, B AND C BARS ARE CENTERED PER L.F. OF BARREL LENGTH.
FOR 0 SKEW END SECTIONS, ADJUST BAR QUANTITIES AS SHOWN ON END SECTION DETAILS, SHEET 2 OF 2. NO ADJUSTMENT IS REQUIRED FOR 30 DEGREE SKEW END SECTIONS.

BASIS OF PAYMENT		
CODE	DESCRIPTION	UNIT
404-00	STRUCTURAL CONCRETE	C.Y.
411-00	REINFORCING STEEL	LBS.
982	PIPE RAILING	L.F.

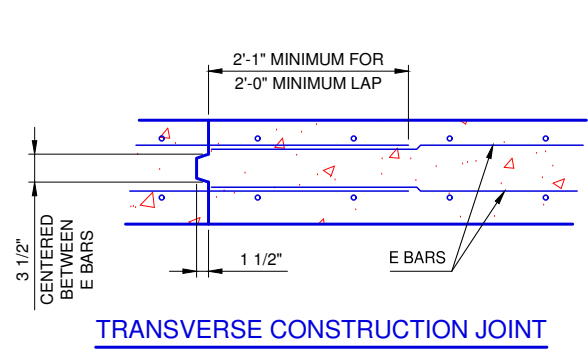

TRANSVERSE CONSTRUCTION JOINT

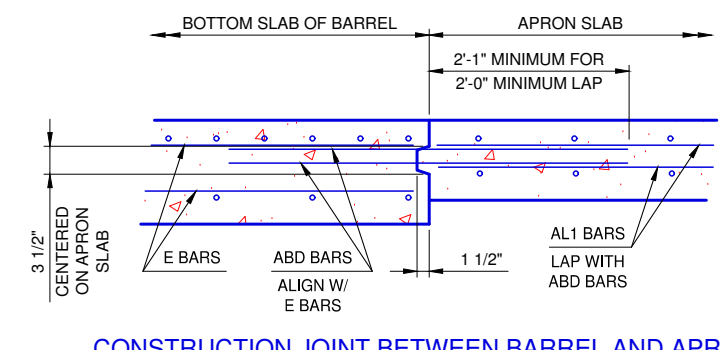

CONSTRUCTION JOINT BETWEEN BARREL AND APRON

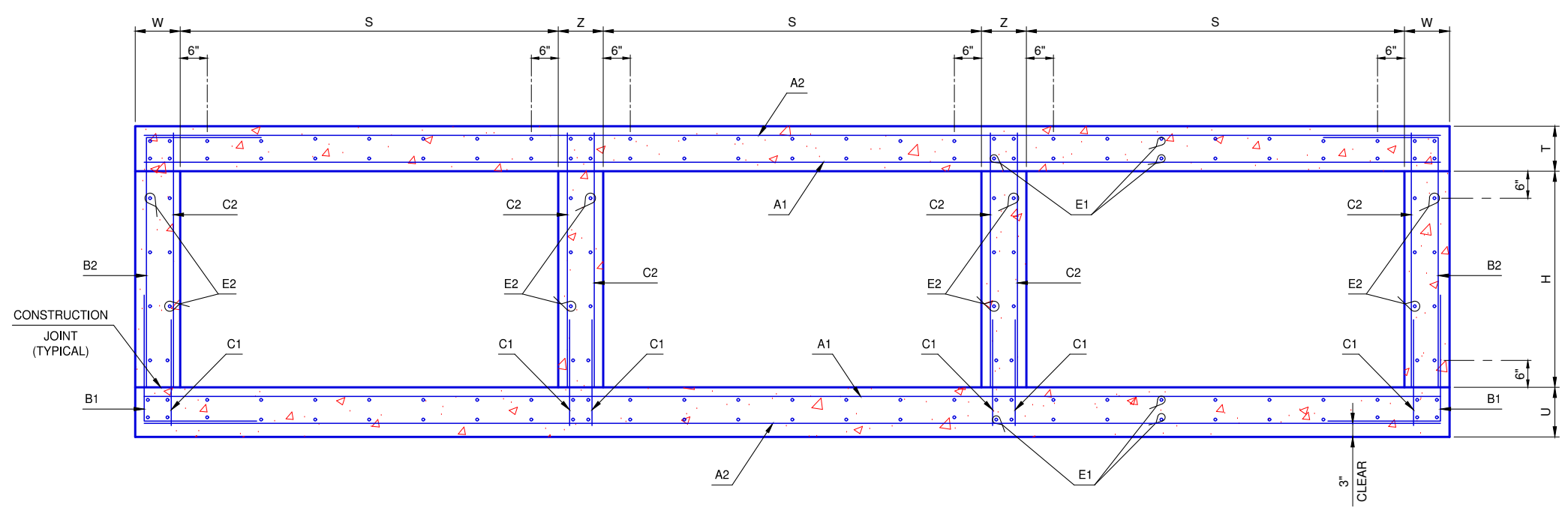
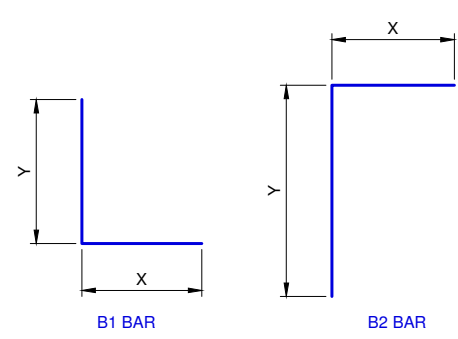

TYPICAL BARREL SECTION

NOTE:
SEE SCHEDULE ON THIS SHEET FOR ACTUAL NUMBER AND SPACING OF E1 AND E2 BARS.

DESIGN DATA
CLASS AA CONCRETE $f_c = 4$ K.S.I.
REINFORCING STEEL $f_y = 60$ K.S.I.

LOADING -
HL-93 LOADING OR OKLAHOMA DEPARTMENT OF TRANSPORTATION OVERLOAD TRUCK
H-20 TRUCK
HS-20 TRUCK
TYPE 3-3 (SPECIAL HAULING VEHICLE)
EV3 (TANDEM REAR AXLE EMERGENCY VEHICLE)
SHV NRL (SPECIAL HAULING VEHICLE NOTIONAL RATING LOAD)
ALL LOAD VEHICLES LISTED, EXCEPT HL-93 AND OKLAHOMA DEPARTMENT OF TRANSPORTATION OVERLOAD TRUCK, WERE ANALYZED USING LOAD FACTOR DESIGN (LFD).

DESIGN -
AASHTO LRFD BRIDGE DESIGN SPECIFICATIONS, 9TH EDITION
AASHTO MANUAL FOR BRIDGE EVALUATION, 3RD EDITION, 2018, WITH 2019 INTERIM REVISIONS

R.C.B. GENERAL NOTES
COMPLY WITH THE REQUIREMENTS OF THE CURRENT THE CITY OF OKLAHOMA CITY STANDARD SPECIFICATIONS.
PROVIDE A 1 1/2" CHAMFER ON ALL EXPOSED CONCRETE EDGES. USE SIZED LUMBER FOR ALL CHAMFER STRIPS.
PROVIDE 2" MINIMUM CLEAR COVER FOR ALL REINFORCING STEEL UNLESS NOTED OTHERWISE.
PLACE TRANSVERSE CONSTRUCTION JOINTS IN ALL CULVERTS 100 FT. OR MORE IN LENGTH AT A MAXIMUM SPACING OF 60 FT. SUBMIT LOCATIONS TO THE CITY ENGINEER FOR APPROVAL. SEE TRANSVERSE CONSTRUCTION JOINT DETAIL ON THIS SHEET.
THE QUANTITY FOR REINFORCING STEEL OF E1 AND E2 BARS DOES NOT INCLUDE LAP SPLICES IN THE LENGTH OF THE BARREL OR AT TRANSVERSE CONSTRUCTION JOINTS WITHIN THE BARREL. COSTS FOR SPLICES WILL NOT BE MEASURED FOR PAYMENT AND WILL BE INCLUDED IN THE CONTRACT UNIT PRICE FOR REINFORCING STEEL.
PIPE RAILING REQUIRED ON TOP OF HEADWALL AND WINGWALLS. SEE STD. RCB-015 PipeRailing.

PLACE WD AND ABD BARS FOR WINGWALLS AND APRON TIED TO BARREL REINFORCING BEFORE PLACING BARREL CONCRETE

REVISION NO.
DATE

APPROVED BY: DATE: 6/22/2023
ERIC J. WENGER, P.E.
CITY ENGINEER

THESE STANDARD DRAWINGS AND ASSOCIATED CALCULATIONS HAVE BEEN PREPARED BY CEC CORPORATION UNDER CONTRACT WITH THE CITY OF OKLAHOMA CITY.

R.C.B. CULVERTS - BARREL DETAILS
4' AND 5' SPANS - TRIPLE CELL
2' TO 10' FILL

Drawing Number
RCB-011

The City of
Oklahoma City
Public Works Department
Engineering Division

