

DRAWING NUMBER	DETAIL DESCRIPTION	SHEET NUMBER	ISSUED DATE
500	WATER STANDARD DETAIL INDEX	500	8/10/2023
501 WATERLINE PIPE			
501.01	BEDDING & TRENCHING	501	8/10/2023
501.02	WATER LINE LOWERING < 24"	501	8/10/2023
501.03	VALVE ABANDONMENT	501	8/10/2023
501.04	TYPICAL PERMANENT CUT AND CAP ON EXISTING WATER LINE	501	8/10/2023
501.05	TYPICAL CUT AND CAP WITH WATER MAIN REMOVAL	501	8/10/2023
501.06	TYPICAL IN-LINE PIPE CUT AND RESTRAINED PLUG	501	8/10/2023
501.07	TYPICAL IN-LINE PIPE CUT AND PLUG	501	8/10/2023
503 WATER SERVICE			
502.01	WATER SERVICE LINE CONNECTION	503	8/10/2023
503.02	SINGLE SHORT SERVICE - REPLACEMENT	503	8/10/2023
503.03	SINGLE SHORT SERVICE - NEW	503	8/10/2023
503.04	SINGLE LONG SERVICE - REPLACEMENT	503	8/10/2023
503.05	SINGLE LONG SERVICE - NEW	503	8/10/2023
504 METER RELOCATION			
504.01	METER RELOCATION	504.A	8/10/2023
504.02	METER BOX FOR GRASSY AREAS	504.A	8/10/2023
504.03	METER BOX FOR SPECIAL APPLICATION PAVED AREAS	504.A	8/10/2023
504.04	METER BOX FOR GRASSY AND PAVED AREAS (TYPE 1)	504.B	8/10/2023
504.05	METER BOX FOR GRASSY AND PAVED AREAS (TYPE 2)	504.B	8/10/2023
504.06	METER BOX FOR GRASSY AND PAVED AREAS (TYPE 3)	504.B	8/10/2023
504.07	WATER METER VAULT	504.C	8/10/2023
504.08	WATER METER VAULT	504.C	8/10/2023
504.09	WATER METER VAULT	504.C	8/10/2023
505 TAPPING CONNECTIONS			
505.01	TAPPING CONNECTION	505	8/10/2023
506 FIRELINES			
506.01	FIRE ASSEMBLY METER VAULT LAYOUT	506	8/10/2023
506.02	FIRE ASSEMBLY METER VAULT LID LAYOUT	506	8/10/2023
506.03	FIRE ASSEMBLY METER VAULT	506	8/10/2023
507 FIRE HYDRANT			
507.01	FIRE HYDRANT	507	8/10/2023
507.02	BOLLARD INSTALLATION	507	8/10/2023
507.03	FIRE HYDRANT 2.5" NOZZLE	507	8/10/2023
507.04	FIRE HYDRANT 5" NOZZLE	507	8/10/2023
507.05	FIRE HYDRANT CONNECTION TO MAIN	507	8/10/2023
507.05.A	ALTERNATE - VERTICAL SHOE	507	8/10/2023
509 THRUST RESTRAINTS			
509.01	RESTRAINING 90° BEND	509.A	8/10/2023
509.02	RESTRAINING 45° BEND	509.A	8/10/2023
509.03	RESTRAINING 22 1/2° BEND	509.A	8/10/2023
509.04	RESTRAINING 11 1/4° BEND	509.A	8/10/2023
509.05	RESTRAINING TEE FITTING	509.B	8/10/2023
509.06	RESTRAINING REDUCER FITTING	509.B	8/10/2023
509.07	RESTRAINING VALVE CONNECTION	509.B	8/10/2023
509.08	RESTRAINING HORIZONTAL OR VERTICAL OFFSETS	509.B	8/10/2023
512 VALVE BOX			
512.01	VALVE AND VALVE BOX	512.A	8/10/2023
512.02	CAST IRON VALVE BOX	512.A	8/10/2023
512.03	CAST IRON VALVE BOX	512.A	8/10/2023
512.04	2" AIR RELEASE VALVE AND VALVE BOX	512.A	8/10/2023
512 VAULT			
512.05	4" AIR RELEASE VALVE AND VAULT	512.B	8/10/2023
512.06	WATER MANHOLE COVER	512.B	8/10/2023
512.07	WATER MANHOLE REVERSIBLE FRAME	512.B	8/10/2023
512.08	VALVE VAULT INSTALLATION	512.C	8/10/2023
515 PVC PIPE			
515.01	PVC PIPE TRACER WIRE INSTALLATION	505	8/10/2023
518 STEEL CASING PIPE			
518.01	PIPE BORING AND CASING INSTALLATION	505	8/10/2023

THESE UTILITIES DEPARTMENT STANDARD DETAILS AS REVISED AND ISSUED ON SEPTEMBER 26, 2023, APPLY TO PROJECTS WHERE: (1) OCWUT, (2) THE CITY OF OKLAHOMA CITY, OR (3) A TRUST OF WHICH THE CITY OF OKLAHOMA CITY IS A BENEFICIARY, IS THE CONTRACTING ENTITY. THE PREVIOUS VERSION OF THE STANDARD DETAILS, ISSUED IN 2014, WILL CONTINUE TO APPLY TO PRIVATE DEVELOPMENT PROJECTS UNTIL THE ISSUANCE OF THE PRIVATE DEVELOPMENT WATER AND WASTEWATER DESIGN REQUIREMENTS.

THESE UTILITIES DEPARTMENT STANDARD DETAILS WILL GOVERN ALL CONNECTIONS AND EXTENSIONS TO THE OKLAHOMA CITY WATER AND WASTEWATER SYSTEMS UNLESS (1) EXPRESSLY STATED IN THE SPECIAL PROVISIONS FOR A PROJECT TO WHICH THE OCWUT IS A CONTRACTING ENTITY, OR (2) EXPRESSLY STATED IN WRITING ON FINAL PLANS APPROVED BY THE UTILITIES DIRECTOR OR A PROFESSIONAL ENGINEER DESIGNATED BY THE UTILITIES DIRECTOR TO REVIEW OF SUCH PLANS.

THESE UTILITIES DEPARTMENT STANDARD DETAILS SUPPLEMENT THE STANDARD SPECIFICATIONS FOR CONSTRUCTION OF PUBLIC IMPROVEMENTS.

WHERE THESE UTILITIES DEPARTMENT STANDARD DETAILS AND THE STANDARD SPECIFICATIONS FOR CONSTRUCTION OF PUBLIC IMPROVEMENTS CONFLICT THESE UTILITIES DEPARTMENT STANDARD DETAILS SUPERSEDE AND TAKE PRECEDENCE OVER THE STANDARD SPECIFICATIONS FOR CONSTRUCTION OF PUBLIC IMPROVEMENTS.

ANY INTERPRETATION OF THE APPLICATION OF THESE UTILITIES DEPARTMENT STANDARD DETAILS WILL BE MADE BY THE UTILITIES DIRECTOR OR A PROFESSIONAL ENGINEER DESIGNATED BY THE UTILITIES DIRECTOR TO REVIEW OF SUCH PLANS.

THE OFFICIAL COPIES OF THE UTILITIES DEPARTMENT STANDARD DETAILS ARE AVAILABLE ON THE UTILITIES DEPARTMENT WEBSITE.

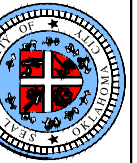

APPROVED BY:
 10/16/2023 DATE: _____
 DEBRA K. MILLER, P.E., INTERIM CITY ENGINEER
 10/10/2023 DATE: _____
 CHRIS BROWNING, GENERAL MANAGER
 10/10/2023 DATE: _____
 WILL HUGGINS, P.E., DEPUTY DIRECTOR
 UTILITIES ENGINEERING

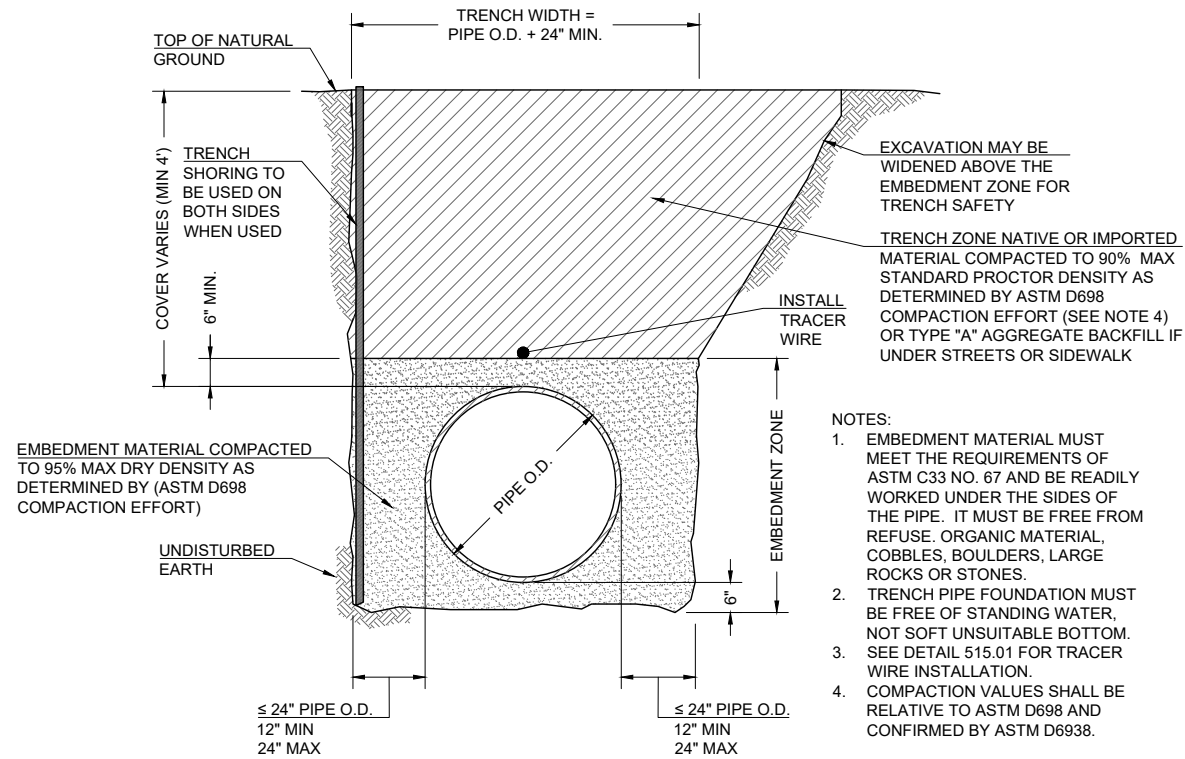

01
501 **BEDDING AND TRENCHING**
Scale: N.T.S.

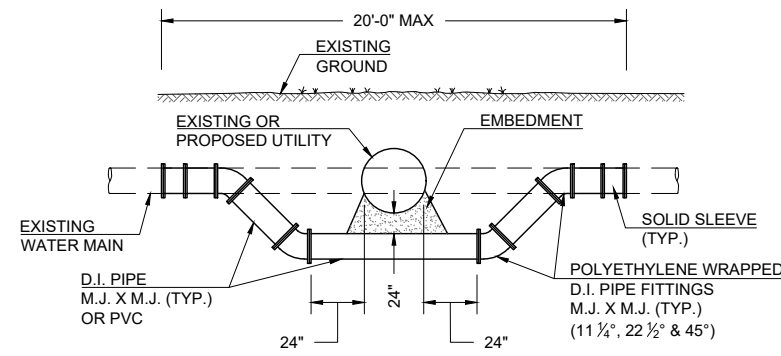

02
501 **WATER LINE LOWERING < 24\"**

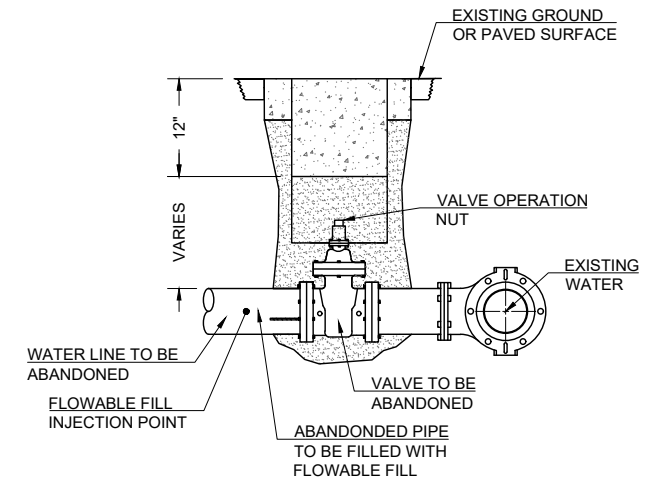

03
501 **VALVE ABANDONMENT**
Scale: N.T.S.

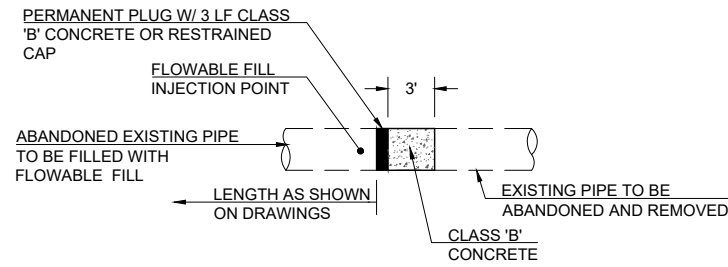

04
501 **TYPICAL PERMANENT CUT AND CAP ON EXISTING WATER LINE**
Scale: N.T.S.

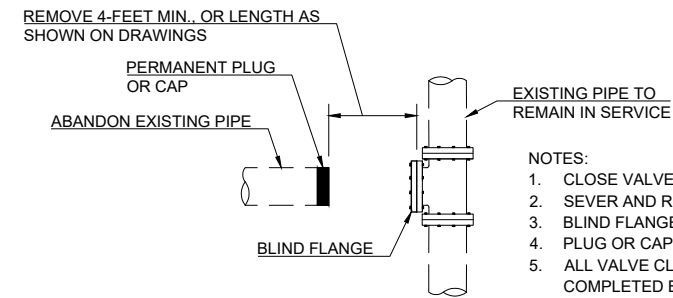

05
501 **TYPICAL CUT AND CAP WITH WATER MAIN REMOVAL**
Scale: N.T.S.

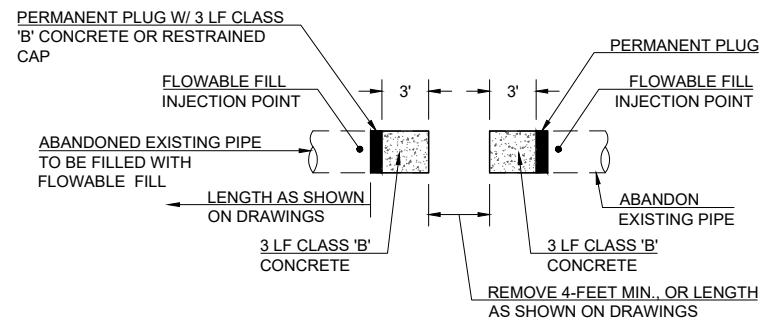

06
501 **TYPICAL IN-LINE PIPE CUT AND RESTRAINED PLUG**
Scale: N.T.S.

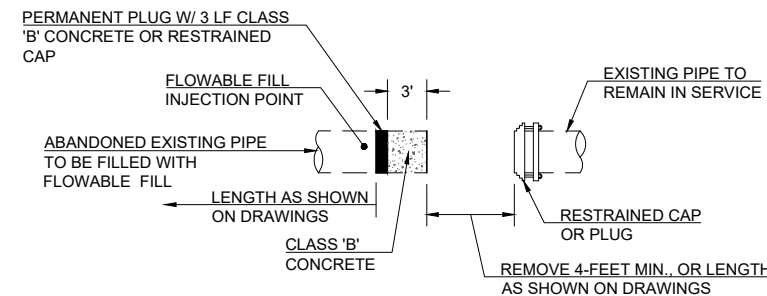

07
501 **TYPICAL IN-LINE PIPE CUT AND PLUG**
Scale: N.T.S.

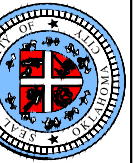

APPROVED BY:
DEBORAH K. MILLER, P.E., INTERIM CITY ENGINEER
CHRIS BROWNING, GENERAL MANAGER
WILL HUGHINS, P.E., DEPUTY DIRECTOR UTILITIES ENGINEERING

DATE: 10/16/2023
DATE: 10/10/2023
DATE: 10/10/2023

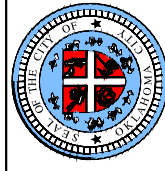

APPROVED BY:
 DEBORAH K. WILKES, P.E., INTERIM CITY ENGINEER
 CHRIS BROWNING, GENERAL MANAGER
 WILL HUGGINS, P.E., DEPUTY DIRECTOR
 UTILITIES ENGINEERING

DATE: 10/16/2023
 DATE: 10/10/2023
 DATE: 10/10/2023

WATER STANDARD DETAILS
 WATER SERVICE
 DETAILS 503.01 TO 503.05

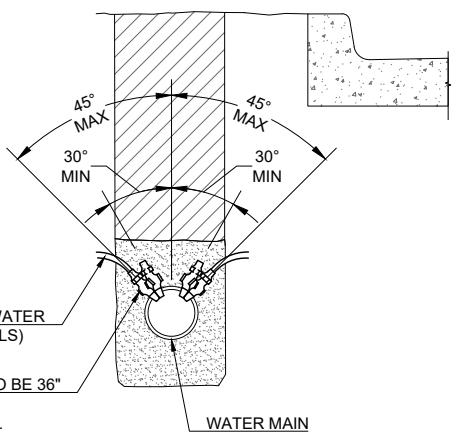

SERVICE LINE (SEE WATER SERVICE LINES DETAILS)
 CORPORATION STOP TAPS TO BE 36" FROM ANY EXISTING OR NEW SERVICE TAPS AND FITTINGS. CONSECUTIVE TAPS TO BE STAGGERED 15"

NOTES:

- SERVICE SADDLES REQUIRED ON ALL TAPS UNLESS OTHERWISE SPECIFIED.
- SERVICE SADDLES TO BE DOUBLE BAND STAINLESS STEEL SADDLES.

01
 503 WATER SERVICE LINE CONNECTION
 Scale: N.T.S.

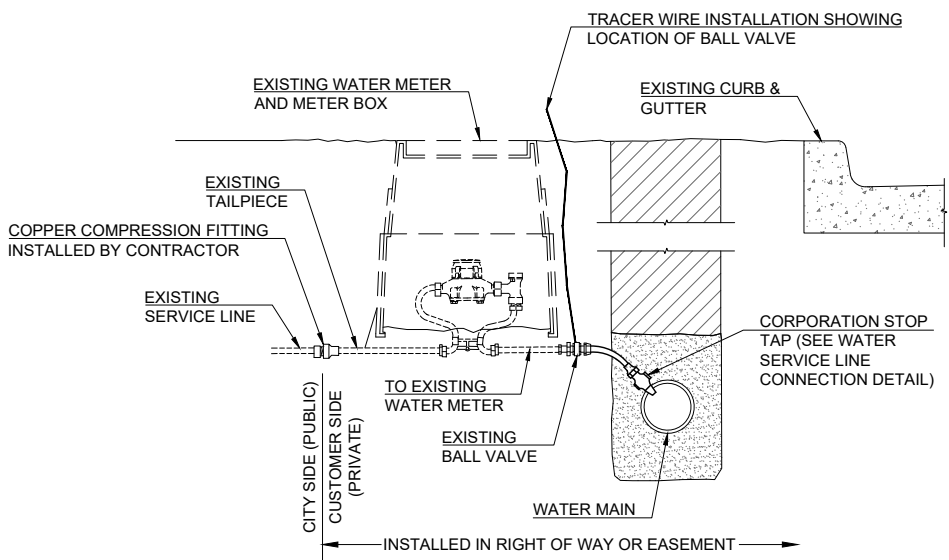

NOTE:

- SINGLE SHORT SERVICE LINES ARE DEFINED AS SERVICE LINES FROM THE MAIN TO METER IS 10 FEET OR LESS.
- SHARKBITES ARE NOT ALLOWED, IF PLUMBER REMOVES THE CITY'S FITTING, IT WILL BECOME THE CUSTOMERS RESPONSIBILITY.

02
 503 SINGLE SHORT SERVICE - REPLACEMENT
 Scale: N.T.S.

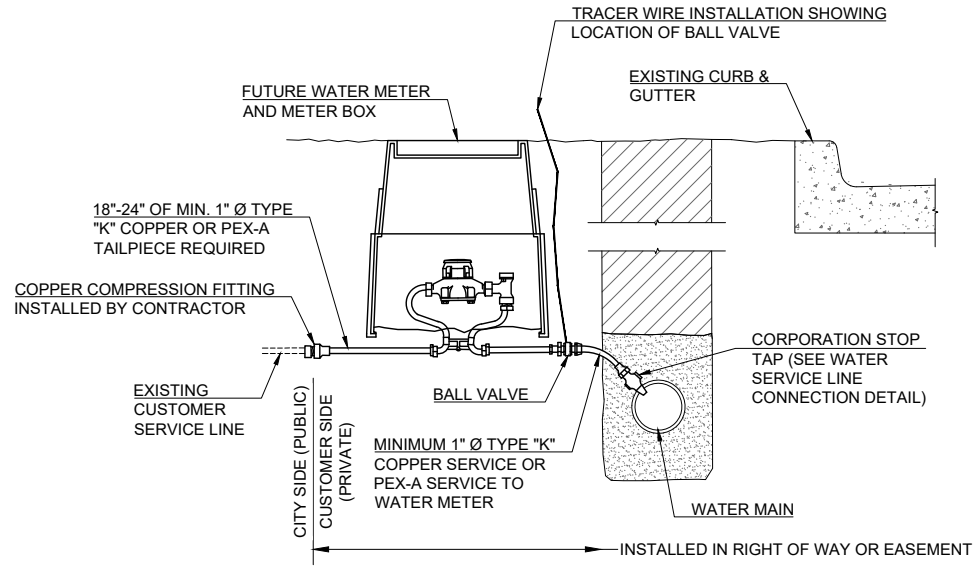

NOTE:

- SINGLE SHORT SERVICE LINES ARE DEFINED AS SERVICE LINES FROM THE MAIN TO METER IS 10 FEET OR LESS.
- SHARKBITES ARE NOT ALLOWED, IF PLUMBER REMOVES THE CITY'S FITTING, IT WILL BECOME THE CUSTOMERS RESPONSIBILITY.

03
 503 SINGLE SHORT SERVICE - NEW
 Scale: N.T.S.

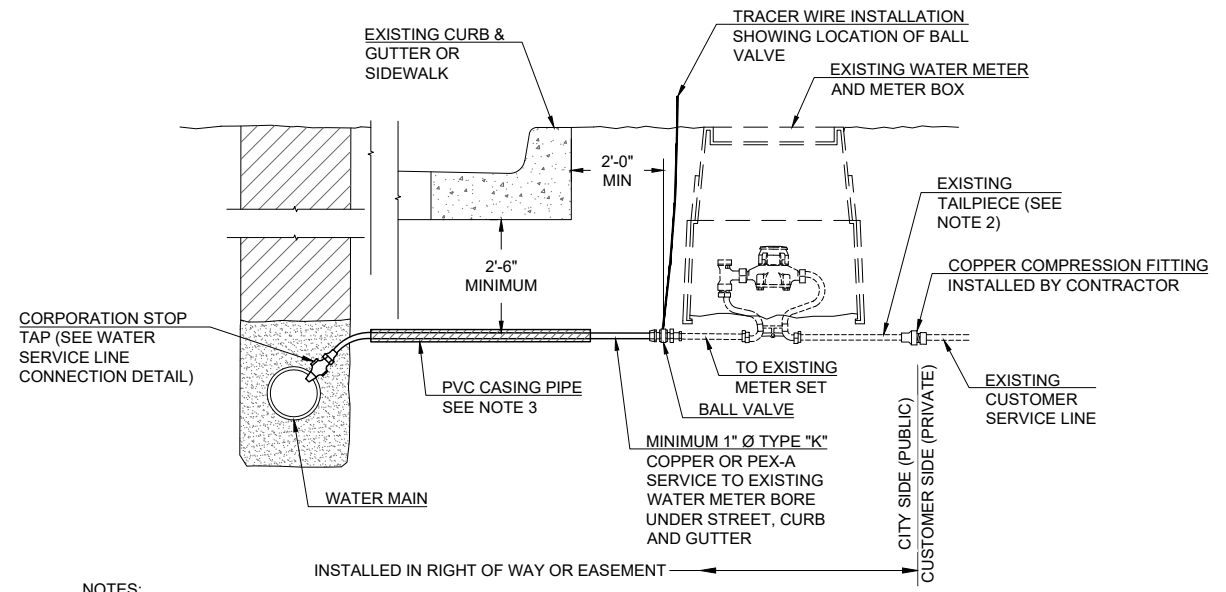

NOTES:

- SINGLE LONG SERVICE LINES ARE DEFINED AS SERVICE LINES FROM THE MAIN TO METER THAT ARE 10-20 FEET. ANYTHING OVER 20 FEET IS CLASSIFIED AS AN EXTRA LONG SERVICE.
- SHARKBITES ARE NOT ALLOWED, IF PLUMBER REMOVES THE CITY'S FITTING, IT WILL BECOME THE CUSTOMERS RESPONSIBILITY.
- PVC CASING PIPE REQUIRED FOR STREET CROSSING IF PEX-A PIPE IS USED FOR SERVICE LINE.

04
 503 SINGLE LONG SERVICE - REPLACEMENT
 Scale: N.T.S.

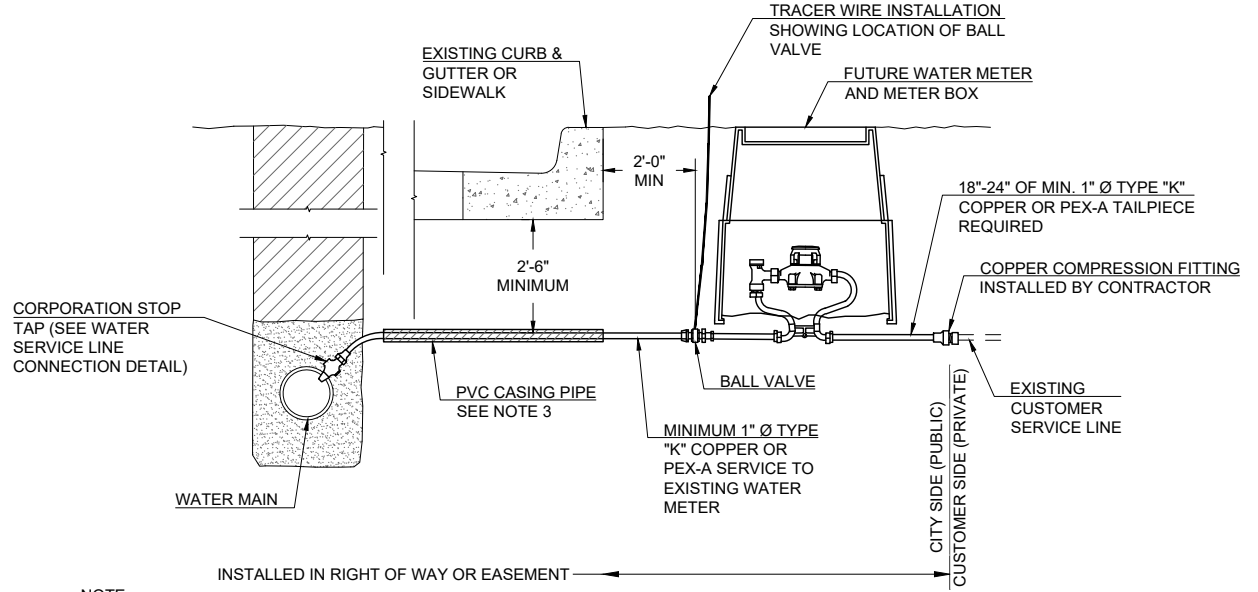

NOTE:

- SINGLE LONG SERVICE LINES ARE DEFINED AS SERVICE LINES FROM THE MAIN TO METER THAT ARE 10-20 FEET. ANYTHING OVER 20 FEET IS CLASSIFIED AS AN EXTRA LONG SERVICE.
- SHARKBITES ARE NOT ALLOWED, IF PLUMBER REMOVES THE CITY'S FITTING, IT WILL BECOME THE CUSTOMERS RESPONSIBILITY.
- PVC CASING PIPE REQUIRED FOR STREET CROSSING IF PEX-A PIPE IS USED FOR SERVICE LINE.

05
 503 SINGLE LONG SERVICE - NEW
 Scale: N.T.S.

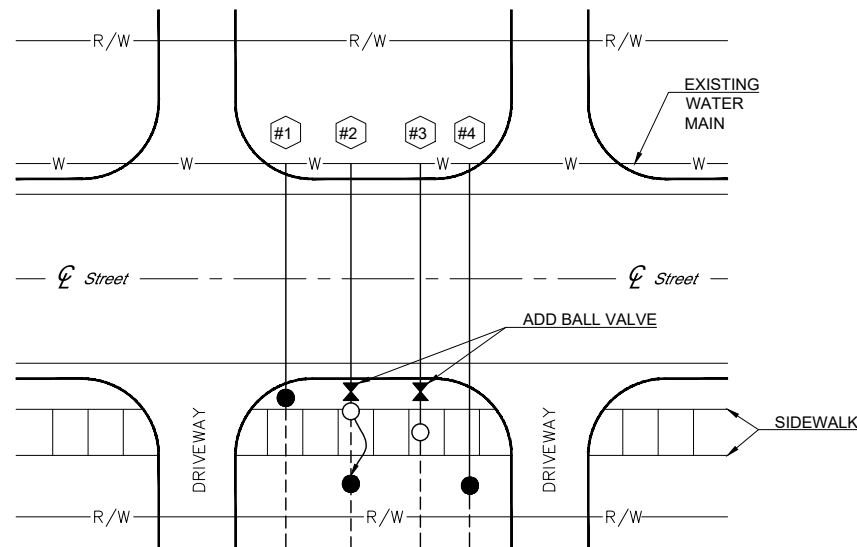

- #1 METER FALLS BETWEEN CURB AND PROPOSED SIDEWALK.
 - NO ACTION REQUIRED.
- #2 METER FALLS PARTIALLY WITHIN PROPOSED SIDEWALK OR WHEN THE OUTSIDE OF THE METER LID IS WITHIN 6" OF THE THE SIDEWALK EDGE. (NOT PERMITTED FOR NEW INSTALLATION)
 - CUT EXISTING SERVICE LINE AND INSTALL BALL VALVE 1'-0" BACK OF CURB.
 - EXTEND SERVICE LINE AND RELOCATE METER WITH NEW TILE BEHIND SIDEWALK.
 - RECONNECT NEW SERVICE LINE TO CUSTOMER'S EXISTING SERVICE LINE, WITHIN CITY RIGHT OF WAY OR EASEMENT.
- #3 METER FALLS WITHIN THE CENTER AREA OF PROPOSED SIDEWALK OR ADA RAMP, NOT WITHIN 6" OF SIDEWALK EDGE. (NOT PERMITTED FOR NEW INSTALLATION OF SIDEWALK OR NEW INSTALLATION OF METER)
 - REPLACE EXISTING METER TILE WITH APPROVED TRAFFIC RATED TILE.
- #4 METER FALLS ON CUSTOMER'S SIDE OF PROPOSED SIDEWALK.
 - NO RELOCATION REQUIRED.

DOMESTIC METER RELOCATION REQUIREMENTS APPLY TO BOTH LONG AND SHORT SERVICES. SHORT SERVICE METER RELOCATION WILL REQUIRE A NEW SERVICE LINE FROM THE MAIN TO THE METER LOCATION WITHOUT THE BALL VALVE INSTALLATION REQUIREMENT. IF LEAD IS FOUND IT MUST BE REPORTED TO THE OKC WATER UTILITIES DEPARTMENT.

01
504 METER RELOCATION
Scale: N.T.S.

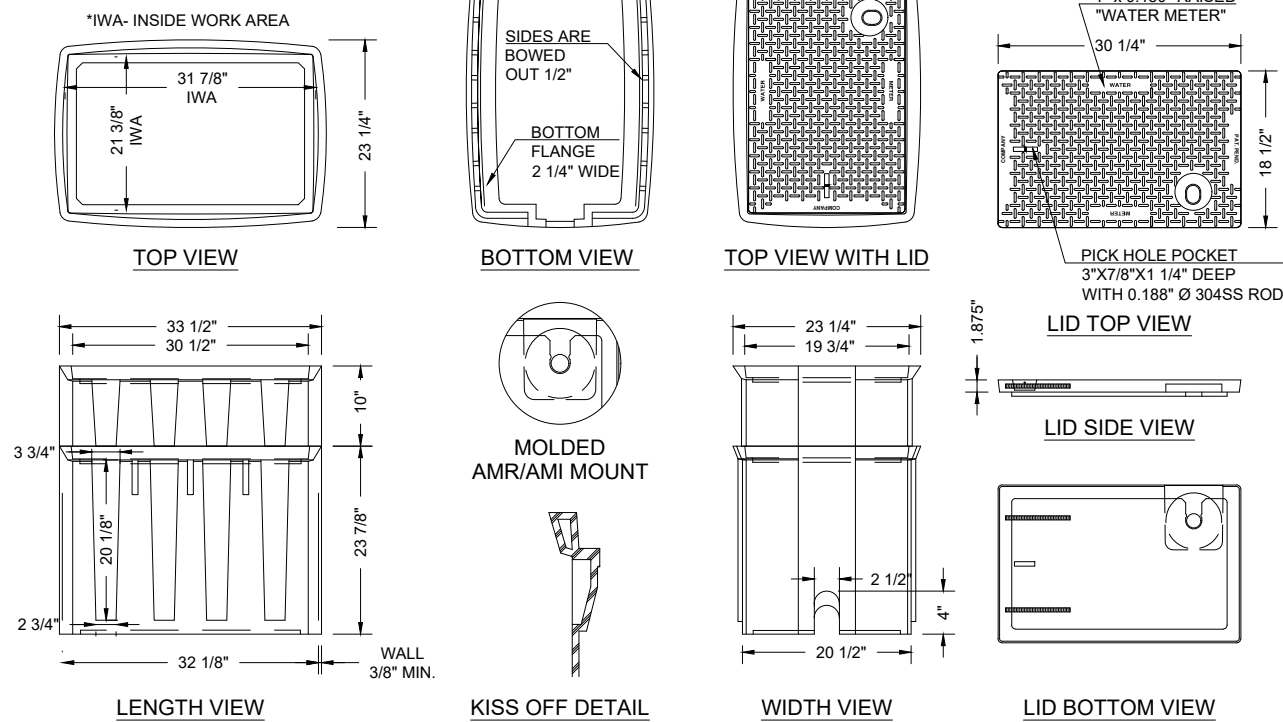

TYPICAL SPECIFICATIONS:
 THE METER BOX MUST BE HIGH-DENSITY POLYETHYLENE OF ONE-PIECE MOLDED CONSTRUCTION WITHOUT A FOAMING AGENT FOR DURABILITY AND IMPACT STRENGTH AND MUST HAVE A SINGLE WALL DESIGN. THE METER BOX MUST BE ABLE TO WITHSTAND AN H-20 LOADING IN NON DELIBERATE OR INCIDENTAL TRAFFIC AREAS. THE METER BOX MUST BE BLACK TO PREVENT UV DEGRADATION. THE BOX MUST HAVE CRUSH RESISTANT RIBBING ALONG THE OUTSIDE OF THE BOX. THE BOX MUST BE DESIGNED IN SUCH A WAY AS TO HAVE AN INTEGRAL FLANGE TYPE LID AS SPECIFIED ON THE DRAWING. THE BOX MUST HAVE REMOVABLE PRE-CUT PIPE ENTRY AREAS LOCATED ON THE CENTER OF EACH END (SHORT SIDE) OF THE BOX FOR SINGLE METER INSTALLATIONS. THE BOX MUST BE DESIGNED IN SUCH A WAY AS TO BE SECURELY STACKABLE. THE BOX MUST WEIGH NO LESS THAN 46 LBS FOR 24" HEIGHT AND NO LESS THAN 72 LBS FOR 34" HEIGHT FOR SAFETY AND EASE OF HANDLING, TRANSPORT AND INSTALLATION. ALL DIMENSIONS ARE MINIMUM PRODUCTION MEASUREMENTS AND MUST BE IN ACCORDANCE WITH THE ABOVE DRAWING (S) FOR THE APPROPRIATE SIZE METER. COVER MUST BE ANTI-FLOAT BLACK REBAR MOLDED POLYMER LID OR BLACK OVERLAY WITH A 0.25" METAL PLATE WITH A SINGLE WALL DESIGN AND A MINIMUM WALL DESIGN AND MINIMUM THICKNESS AS SPECIFIED. THE LID WEIGHT MUST BE A MINIMUM OF 43 LBS. THE LID MUST NOT HAVE A FOAMING PLASTIC OR BLOWING AGENT THAT CREATES AIR POCKETS. LID MUST CONTAIN A MOLDED KEY HOLE DESIGN. LID MUST HAVE AN INTEGRAL MOLDED SLIDE MOUNT FOR AMR DEVICE AND MUST BE MOLDED AS A ONE PIECE UNIT AS SPECIFIED IN THE ABOVE DRAWING. THE LID MUST CONTAIN THE TREAD PATTEN AS ILLUSTRATED WITH DIMENSION PER TREAD OF 0.188" X 0.938" X 0.150" DEEP. LID MUST CONTAIN THE NAME OF THE MANUFACTURER AND PART NUMBER. THE METER BOX AND LID MUST BE MANUFACTURED BY DFW PLASTICS, INC. OR APPROVED EQUAL.

03
504 METER BOX FOR SPECIAL APPLICATION PAVED AREAS
Scale: N.T.S.

02
504 METER BOX FOR GRASSY AREA
Scale: N.T.S.

The City of Oklahoma City
 Utilities Department
 Engineering Division

APPROVED BY: *Debra Miller* DATE: 10/16/2023
 DEBRA MILLER, P.E., INTERIM CITY ENGINEER
Chris Browning DATE: 10/10/2023
 CHRIS BROWNING, GENERAL MANAGER
Will Huggins DATE: 10/10/2023
 WILL HUGGINS, P.E., DEPUTY DIRECTOR
 UTILITIES ENGINEERING

WATER STANDARD DETAILS
 METER RELOCATION
 DETAILS 504.01 TO 504.03

504.A

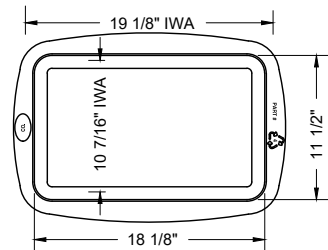

TOP VIEW

*IWA- INSIDE WORK AREA

HEIGHT	A	B	C
12"	3 1/2"	2 1/2"	7 5/8"
18"	3 3/8"	2 3/8"	13 1/2"

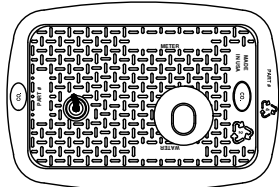

TOP VIEW WITH LID

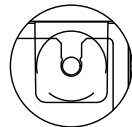

MOLDED AMR/AMI MOUNT

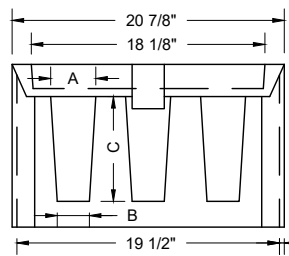

LENGTH VIEW

WALL 3/8" MIN.

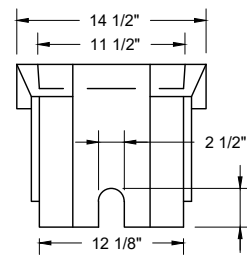

WIDTH VIEW

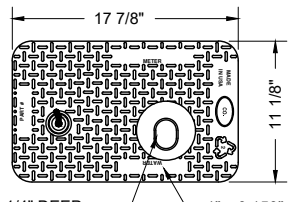

LID TOP VIEW

Ø4.625" x 1/4" DEEP RECESS FOR AMR PAD W/ Ø1.88" x 2 1/2" SLOT KNOCK OUT FOR AMR

1" x 0.150" RAISED "WATER METER"

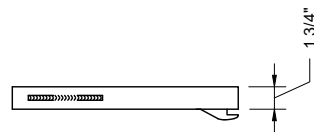

LID SIDE VIEW

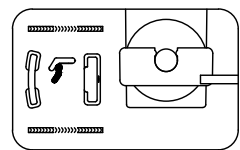

LID BOTTOM VIEW

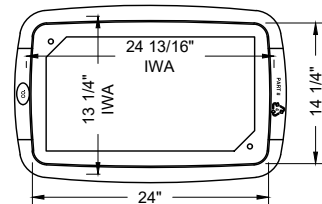

TOP VIEW

*IWA- INSIDE WORK AREA

HEIGHT	A	B	C
12"	3 1/2"	2 5/8"	7 7/8"
18"	3 3/8"	2 1/2"	13 7/8"

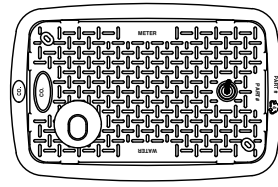

TOP VIEW WITH LID

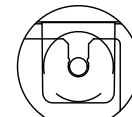

MOLDED AMR/AMI MOUNT

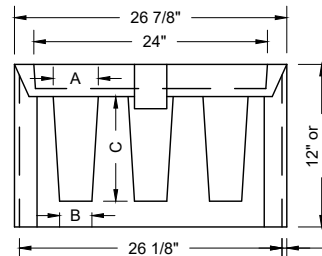

LENGTH VIEW

WALL 3/8" MIN.

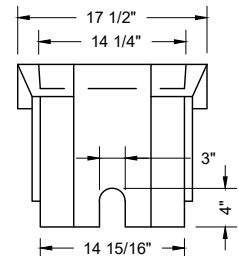

WIDTH VIEW

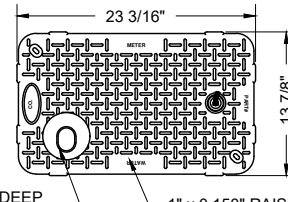

LID TOP VIEW

Ø4.625" x 0.25" DEEP RECESS FOR AMR PAD W/ Ø1.88" x 2.50" SLOT KNOCK OUT FOR AMR

1" x 0.150" RAISED "WATER METER"

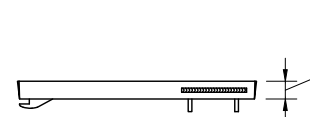

LID SIDE VIEW

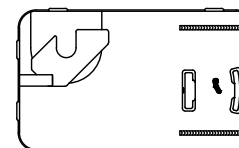

LID BOTTOM VIEW

TYPICAL SPECIFICATIONS:

THE METER BOX MUST BE HIGH-DENSITY POLYETHYLENE OF ONE-PIECE MOLDED CONSTRUCTION WITHOUT A FOAMING AGENT FOR DURABILITY AND IMPACT STRENGTH AND MUST HAVE A SINGLE WALL DESIGN. THE METER BOX MUST BE ABLE TO WITHSTAND AN H-20 LOADING IN NON DELIBERATE OR INCIDENTAL TRAFFIC AREAS. THE METER BOX MUST BE BLACK TO PREVENT UV DEGRADATION. THE BOX MUST HAVE CRUSH RESISTANT RIBBING ALONG THE OUTSIDE OF THE BOX. THE BOX MUST BE DESIGNED IN SUCH A WAY AS TO HAVE AN INTEGRAL FLANGE TYPE LID AS SPECIFIED ON THE DRAWING. THE BOX MUST HAVE REMOVABLE PRE-CUT PIPE ENTRY AREAS LOCATED ON THE CENTER OF EACH END (SHORT SIDE) OF THE BOX FOR SINGLE METER INSTALLATIONS. THE BOX MUST BE DESIGNED IN SUCH A WAY AS TO BE SECURELY STACKABLE. THE BOX MUST WEIGH NO LESS THAN 15 LBS FOR 12" HEIGHT AND NO LESS THAN 18 LBS FOR 18" HEIGHT FOR SAFETY AND EASE OF HANDLING, TRANSPORT AND INSTALLATION. ALL DIMENSIONS ARE MINIMUM PRODUCTION MEASUREMENTS AND MUST BE IN ACCORDANCE WITH THE ABOVE DRAWING (S) FOR THE APPROPRIATE SIZE METER. COVER MUST BE ANTI-FLOAT BLACK REBAR MOLDED POLYMER LID WITH A SINGLE WALL DESIGN AND A MINIMUM WALL DESIGN AND MINIMUM THICKNESS AS SPECIFIED. THE LID WEIGHT MUST BE A MINIMUM OF 13 LBS. THE LID MUST NOT HAVE A FOAMING PLASTIC OR BLOWING AGENT THAT CREATES AIR POCKETS. LID MUST CONTAIN A MOLDED KEY HOLE DESIGN. LID MUST HAVE AN INTEGRAL MOLDED SLIDE MOUNT FOR AMR DEVICE AND MUST BE MOLDED AS A ONE PIECE UNIT AS SPECIFIED IN THE ABOVE DRAWING. THE LID MUST CONTAIN THE TREAD PATTEN AS ILLUSTRATED WITH DIMENSION PER TREAD OF 0.188" X 0.938" X 0.150" DEEP. LID MUST CONTAIN THE NAME OF THE MANUFACTURER AND PART NUMBER. THE METER BOX AND LID MUST BE MANUFACTURED BY DFW PLASTICS, INC. OR APPROVED EQUIVALENT.

METER BOX FOR GRASS AND PAVED AREAS (TYPE 1)

04
504

Scale: N.T.S.

TYPICAL SPECIFICATIONS:

THE METER BOX MUST BE HIGH-DENSITY POLYETHYLENE OF ONE-PIECE MOLDED CONSTRUCTION WITHOUT A FOAMING AGENT FOR DURABILITY AND IMPACT STRENGTH AND MUST HAVE A SINGLE WALL DESIGN. THE METER BOX MUST BE ABLE TO WITHSTAND AN H-20 LOADING IN NON DELIBERATE OR INCIDENTAL TRAFFIC AREAS. THE METER BOX MUST BE BLACK TO PREVENT UV DEGRADATION. THE BOX MUST HAVE CRUSH RESISTANT RIBBING ALONG THE OUTSIDE OF THE BOX. THE BOX MUST BE DESIGNED IN SUCH A WAY AS TO HAVE AN INTEGRAL FLANGE TYPE LID AS SPECIFIED ON THE DRAWING. THE BOX MUST HAVE REMOVABLE PRE-CUT PIPE ENTRY AREAS LOCATED ON THE CENTER OF EACH END (SHORT SIDE) OF THE BOX FOR SINGLE METER INSTALLATIONS. THE BOX MUST BE DESIGNED IN SUCH A WAY AS TO BE SECURELY STACKABLE. THE BOX MUST WEIGH NO LESS THAN 19 LBS FOR 12" HEIGHT AND NO LESS THAN 27 LBS FOR 18" HEIGHT FOR SAFETY AND EASE OF HANDLING, TRANSPORT AND INSTALLATION. ALL DIMENSIONS ARE MINIMUM PRODUCTION MEASUREMENTS AND MUST BE IN ACCORDANCE WITH THE ABOVE DRAWING (S) FOR THE APPROPRIATE SIZE METER. COVER MUST BE ANTI-FLOAT BLACK REBAR MOLDED POLYMER LID WITH A SINGLE WALL DESIGN AND A MINIMUM WALL DESIGN AND MINIMUM THICKNESS AS SPECIFIED. THE LID WEIGHT MUST BE A MINIMUM OF 21 LBS. THE LID MUST NOT HAVE A FOAMING PLASTIC OR BLOWING AGENT THAT CREATES AIR POCKETS. LID MUST CONTAIN A MOLDED KEY HOLE DESIGN. LID MUST HAVE AN INTEGRAL MOLDED SLIDE MOUNT FOR AMR DEVICE AND MUST BE MOLDED AS A ONE PIECE UNIT AS SPECIFIED IN THE ABOVE DRAWING. THE LID MUST CONTAIN THE TREAD PATTEN AS ILLUSTRATED WITH DIMENSION PER TREAD OF 0.188" X 0.938" X 0.150" DEEP. LID MUST CONTAIN THE NAME OF THE MANUFACTURER AND PART NUMBER. THE METER BOX AND LID MUST BE MANUFACTURED BY DFW PLASTICS, INC. OR APPROVED EQUIVALENT.

METER BOX FOR GRASS AND PAVED AREAS (TYPE 2)

05
504

Scale: N.T.S.

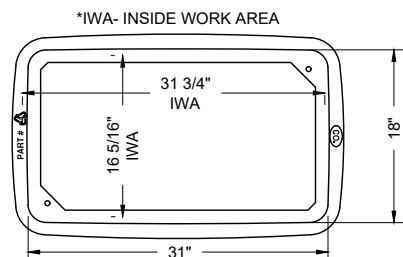

TOP VIEW

HEIGHT	A	B	C
12"	3.125"	2.25"	7 1/2"
18"	3.125"	2.25"	13 1/2"

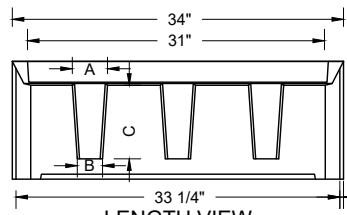

LENGTH VIEW

WALL 3/8" MIN.

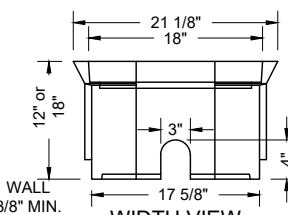

WIDTH VIEW

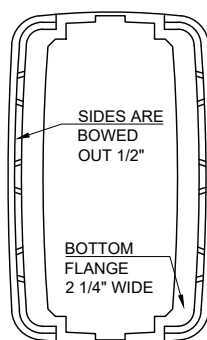

BOTTOM VIEW

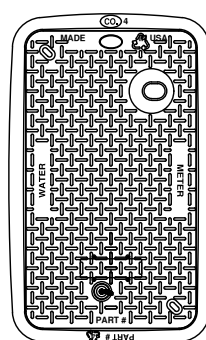

TOP VIEW WITH LID

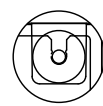

MOLDED AMR/AMI MOUNT

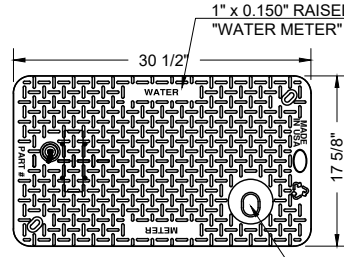

LID TOP VIEW

Ø4.625" x 0.25" DEEP RECESS FOR AMR PAD W/ Ø1.88" x 2.50" SLOT KNOCK OUT FOR AMR

1" x 0.150" RAISED "WATER METER"

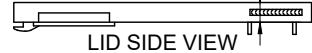

LID SIDE VIEW

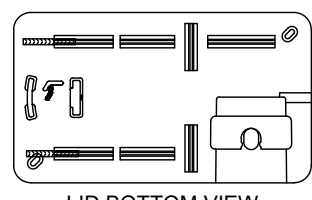

LID BOTTOM VIEW

TYPICAL SPECIFICATIONS:

THE METER BOX MUST BE HIGH-DENSITY POLYETHYLENE OF ONE-PIECE MOLDED CONSTRUCTION WITHOUT A FOAMING AGENT FOR DURABILITY AND IMPACT STRENGTH AND MUST HAVE A SINGLE WALL DESIGN. THE METER BOX MUST BE ABLE TO WITHSTAND AN H-20 LOADING IN NON DELIBERATE OR INCIDENTAL TRAFFIC AREAS. THE METER BOX MUST BE BLACK TO PREVENT UV DEGRADATION. THE BOX MUST HAVE CRUSH RESISTANT RIBBING ALONG THE OUTSIDE OF THE BOX. THE BOX MUST BE DESIGNED IN SUCH A WAY AS TO HAVE AN INTEGRAL FLANGE TYPE LID AS SPECIFIED ON THE DRAWING. THE BOX MUST HAVE REMOVABLE PRE-CUT PIPE ENTRY AREAS LOCATED ON THE CENTER OF EACH END (SHORT SIDE) OF THE BOX FOR SINGLE METER INSTALLATIONS. THE BOX MUST BE DESIGNED IN SUCH A WAY AS TO BE SECURELY STACKABLE. THE BOX MUST WEIGH NO LESS THAN 27 LBS FOR 12" HEIGHT AND NO LESS THAN 36 LBS FOR 18" HEIGHT FOR SAFETY AND EASE OF HANDLING, TRANSPORT AND INSTALLATION. ALL DIMENSIONS ARE MINIMUM PRODUCTION MEASUREMENTS AND MUST BE IN ACCORDANCE WITH THE ABOVE DRAWING (S) FOR THE APPROPRIATE SIZE METER. COVER MUST BE ANTI-FLOAT BLACK REBAR MOLDED POLYMER LID WITH A SINGLE WALL DESIGN AND A MINIMUM WALL DESIGN AND MINIMUM THICKNESS AS SPECIFIED. THE LID WEIGHT MUST BE A MINIMUM OF 44 LBS. THE LID MUST NOT HAVE A FOAMING PLASTIC OR BLOWING AGENT THAT CREATES AIR POCKETS. LID MUST CONTAIN A MOLDED KEY HOLE DESIGN. LID MUST HAVE AN INTEGRAL MOLDED SLIDE MOUNT FOR AMR DEVICE AND MUST BE MOLDED AS A ONE PIECE UNIT AS SPECIFIED IN THE ABOVE DRAWING. THE LID MUST CONTAIN THE TREAD PATTEN AS ILLUSTRATED WITH DIMENSION PER TREAD OF 0.188" X 0.938" X 0.150" DEEP. LID MUST CONTAIN THE NAME OF THE MANUFACTURER AND PART NUMBER. THE METER BOX MUST AND LID BE MANUFACTURED BY DFW PLASTICS, INC. OR APPROVED EQUIVALENT.

METER BOX FOR GRASS AND PAVED AREAS (TYPE 3)

06
504

Scale: N.T.S.

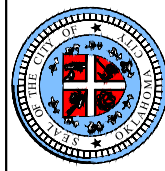

APPROVED BY: *Debra N. Miller* DATE: 10/16/2023
DEBRA N. MILLER, P.E., INTEGRITY CITY ENGINEER
Chris Browning DATE: 10/10/2023
CHRIS BROWNING, GENERAL MANAGER
Will Huggins DATE: 10/10/2023
WILL HUGGINS, P.E., DEPUTY DIRECTOR
UTILITIES ENGINEERING

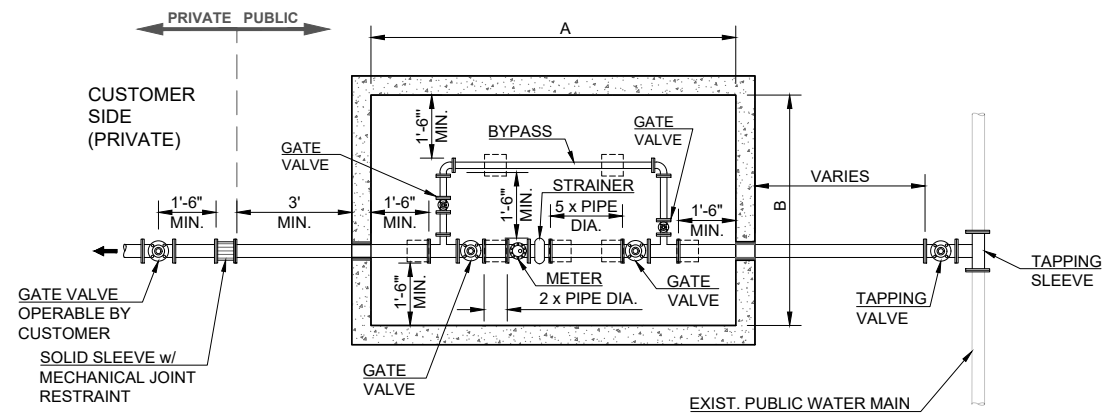

METER SIZE	BY-PASS SIZE	A	B
3"	2"	9'-6"	6'-0"
4"	2"	11'-0"	6'-0"
6"	3"	14'-0"	6'-6"

PLAN VIEW

07
504 **WATER METER VAULT LAYOUT**
Scale: N.T.S.

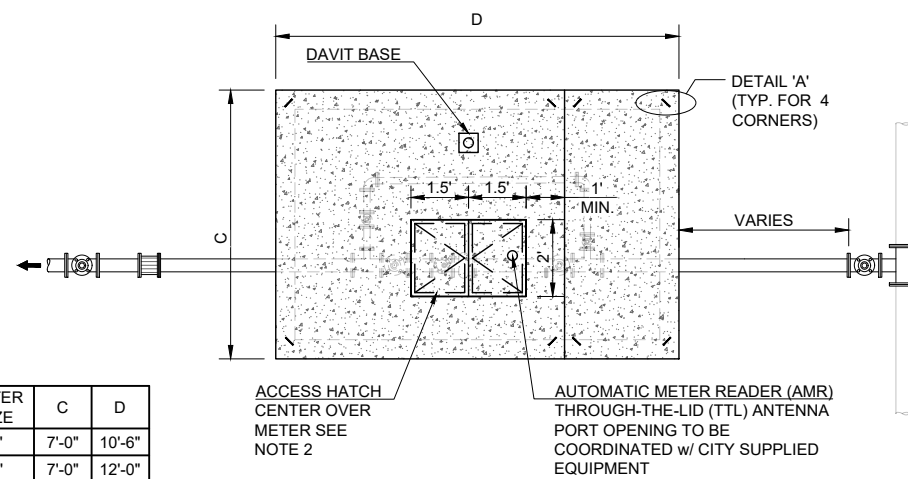

METER SIZE	C	D
3"	7'-0"	10'-6"
4"	7'-0"	12'-0"
6"	7'-6"	15'-0"

PLAN VIEW

08
504 **WATER METER VAULT LID LAYOUT**
Scale: N.T.S.

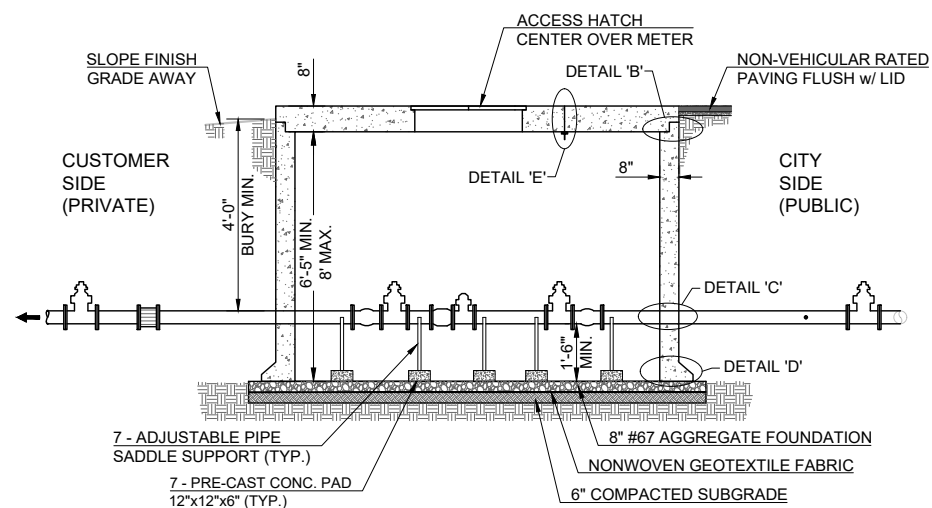

SECTION VIEW

09
504 **WATER METER VAULT**
Scale: N.T.S.

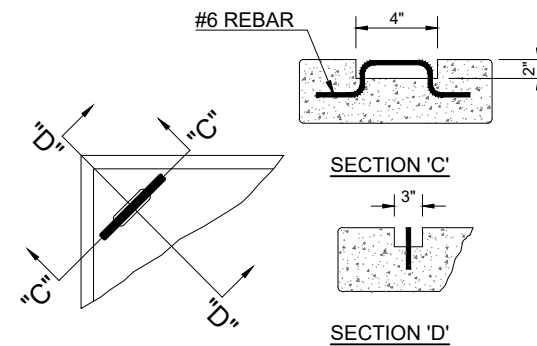

NOTE:
1. PROVIDE LIFTING EYES (4" MIN. PER PRECAST SECTION) BASED ON MIN. CAPACITY OF 2 TON / LIFTING EYE.

LIFTING EYE DETAIL
DETAIL 'A'

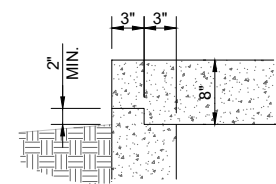

PRECAST JOINT DETAIL
DETAIL 'B'

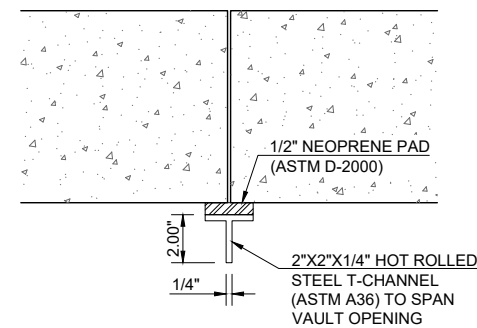

STEEL CHANNEL CONNECTION DETAIL
DETAIL 'E'

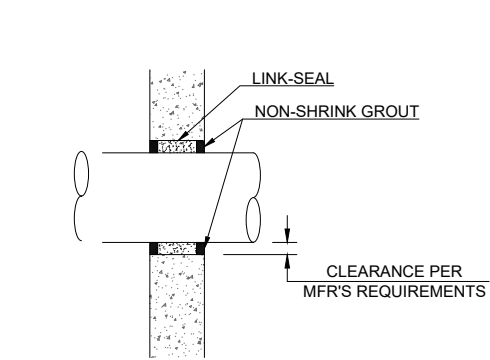

SEAL & GROUT
PIPE WALL PENETRATION DETAIL
DETAIL 'C'

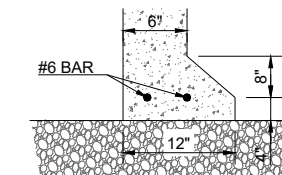

FOOTING DETAIL
DETAIL 'D'

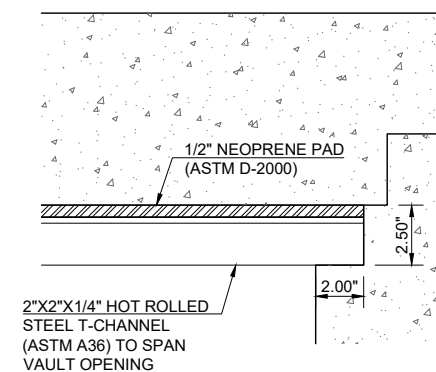

STEEL CHANNEL CONNECTION DETAIL
(ROTATED 90 DEG.)
DETAIL 'F'

GENERAL NOTES:

- ALL CONSTRUCTION MUST BE DONE IN STRICT ACCORDANCE WITH OKLAHOMA CITY'S "STANDARD SPECIFICATIONS FOR CONSTRUCTION OF PUBLIC IMPROVEMENTS" AND MUST BE UNDER THE STRICT SUPERVISION OF THE CITY ENGINEER OF THE CITY OF OKLAHOMA CITY.
- FOR VAULTS LOCATED WITHIN VEHICULAR TRAVELLED SURFACES, THE VAULT MUST BE DESIGNED FOR THE PROPER VEHICLE LOADING CONDITIONS. IN GRASS AREA ACCESS HATCH MUST BE HALLIDAY PRODUCTS SERIES H2R ACCESS DOOR w/ SAFETY FALL GRATING, OR APPROVED EQUAL. IN PAVED AREA ACCESS HATCH MUST BE EAST JORDAN WITH DUCTILE IRON LID (MODEL 00821221B01) w/ SAFETY FALL GRATING, OR APPROVED EQUAL.
- VAULT ACCESS HATCHES OUTSIDE VEHICULAR TRAVELLED SURFACES w/ SAFETY FALL GRATING.
- PRECAST VAULTS MUST BE CONSTRUCTED AS SPECIFIED IN ASTM C857-16 & ASTM C858-18.
- CONCRETE MUST HAVE A MIN. 7 DAY COMPRESSIVE STRENGTH OF 4,000 PSI.
- REINFORCING STEEL MUST BE GRADE 60.
- REINFORCING STEEL MUST HAVE A MIN. 2" CLEAR SPACE FROM EXPOSED SURFACE.
- MINIMUM REINFORCEMENT IN VAULT LID & WALLS MUST BE GRADE 60, #3 BARS AT 9 1/2" CC EW OR GRADE 65 WIRE MESH W6.2 / W6.2, 6"x 6".
- JOINTS BETWEEN PRECAST VAULT SECTIONS (LID TO WALL OR WALL TO WALL) MUST HAVE CONCRETE JOINT SEALANT APPLIED TO THE JOINT PRIOR TO THE SECTIONS BEING ASSEMBLED. SEALANT MUST MEET ASTM C990, U.S. FEDERAL SPECIFICATION SS-5-210A, TYPE 1, ROPE FORM & AASHTO M-198-10.
- SUBGRADE MUST BE COMPACTED TO 95% STD. PROCTOR DENSITY, ASTM D-698.
- GEOTEXTILE FABRIC MUST BE NON-WOVEN POLYPROPYLENE, TENSILE STRENGTH OF 200 LBS.
- AGGREGATE FOUNDATION MUST BE ASTM C-33 #67 COMPACTED TO 95% STD. PROCTOR DENSITY, ASTM D-698.
- PRECAST VAULTS MUST BE INSTALLED AS SPECIFIED IN ASTM C891-11.
- ALL FITTINGS WITHIN VAULT MUST BE FLANGED.
- ALL FITTINGS & PIPE OUTSIDE OF VAULT MUST BE RESTRAINED FITTINGS.
- ADJUSTABLE PIPE SADDLE SUPPORT w/ THREADED PIPE STAND w/ ELECTRO-GALVANIZED FINISH MEETING ANSI / MSS SP-69 & SP-58, TYPE 38.
- ALL PIPE & FITTINGS WITHIN THE VAULT MUST BE DUCTILE IRON PIPE (DIP). DIP MUST EXTEND A MINIMUM OF 3' BEYOND THE OUTSIDE FACE OF THE VAULT. WHERE CONNECTING TO PVC PIPE OUTSIDE OF THE VAULT A MECHANICALLY RESTRAINED SOLID SLEEVE OR FITTING MUST BE USED.
- ACCESS HATCH MUST BE HALLIDAY PRODUCTS SERIES H2R ACCESS DOOR, OR APPROVED EQUAL.

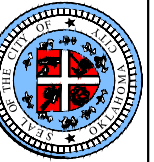

APPROVED BY: *Deborah K. Miller* 10/16/2023
DEBORAH K. MILLER, P.E., INTERIM CITY ENGINEER
Chris Browning 10/10/2023
CHRIS BROWNING, GENERAL MANAGER
Will Huggins 10/10/2023
WILL HUGGINS, P.E., DEPUTY DIRECTOR
UTILITIES ENGINEERING

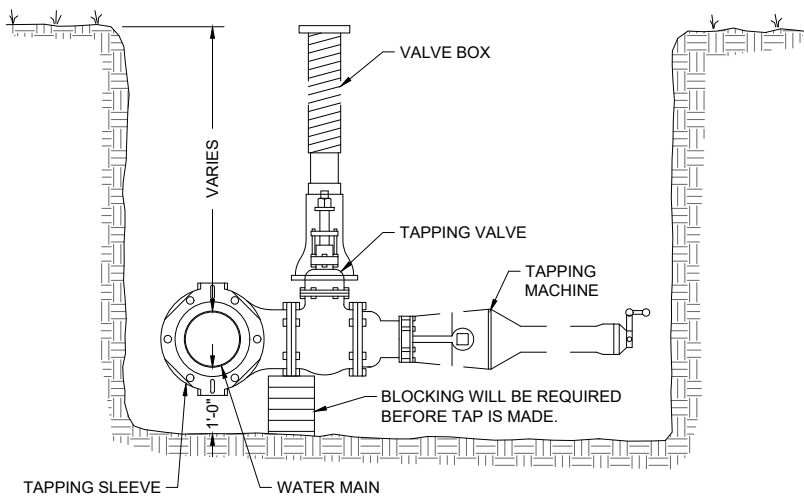

01
505 **TAPPING CONNECTION**
Scale: N.T.S.

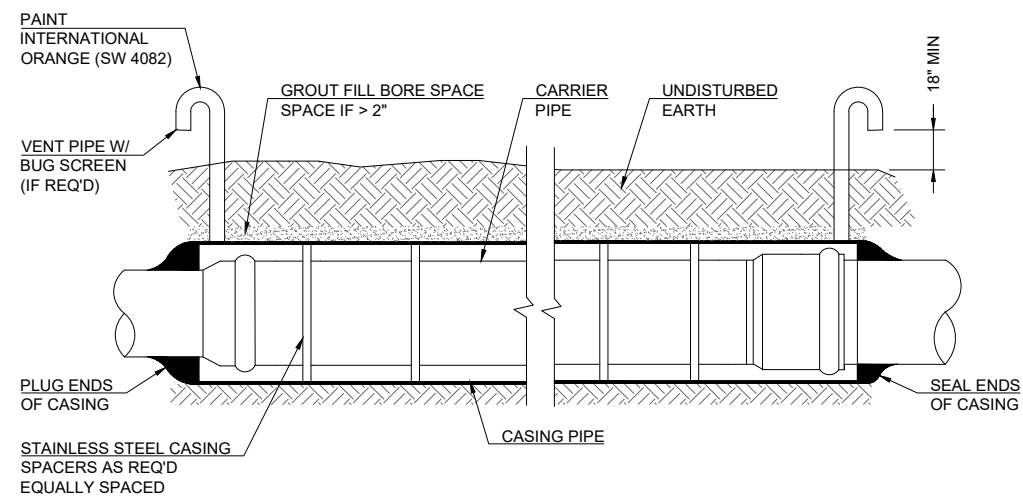

NOTES:

SEALED CASING ENDS - NEOPRENE RUBBER END SEALS SECURED WITH 316 STAINLESS STEEL BANDING REQUIRED

PLUGGED PIPE ENDS - BOTH ENDS OF THE CASING PIPE MUST BE PLUGGED WITH A NON-SHRINK GROUT OR CONCRETE HAVING A MINIMUM COMPRESSIVE STRENGTH OF 2500 PSI OR GROUTED MASONRY. EACH PLUG MUST BE A MINIMUM LENGTH OF 18". GROUTING PRESSURE MUST NOT EXCEED THE PIPE MANUFACTURER'S RECOMMENDATIONS.

VENT PIPES - VENT PIPES MUST BE INSTALLED ON BOTH ENDS OF CASING FOR BORINGS THAT CROSS ODOT ROADS AND RAILROAD CROSSINGS. VENTS MUST BE 2" DIA. FOR CASING SIZES ≤ 30-IN. VENTS MUST BE 4" DIA. FOR CASING SIZES > 30-IN. VENTS MUST HAVE A 90 DEG BEND TO POINT TOWARDS THE GROUND AND MUST BE PAINTED INTERNATIONAL ORANGE. BUG SCREEN MUST BE INCLUDED ON THE OPEN END OF VENT PIPE.

CASING PIPE SIZE - STEEL CASING PIPE MUST HAVE THE FOLLOWING MINIMUM DIAMETERS: SEE STANDARD SPECIFICATION 518.02.02 OR STANDARD DETAIL 635.02.

CASING PIPE THICKNESS - STEEL CASING PIPE MUST HAVE THE FOLLOWING MINIMUM THICKNESS(ES), IN INCHES, FOR THE INDICATED MAXIMUM DEPTH OF COVER(S), IN FEET: SEE STANDARD SPECIFICATION 518.02.02 OR STANDARD DETAIL 635.02.

CASING MATERIAL - STEEL CASING PIPE MUST CONFORM WITH ASTM A-139, STANDARD SPECIFICATION FOR ELECTRIC-FUSION (ARC) - WELDED STEEL PIPE (NPS4 AND OVER). THE STEEL MATERIAL MUST BE NEW, SMOOTH WALL, CARBON STEEL, GRADE B, WITH A MINIMUM TENSILE STRENGTH AND MINIMUM THIRTY-FIVE-THOUSAND (35,000 PSI) POUNDS PER SQUARE INCH YIELD STRENGTH

01
518 **PIPE BORE AND CASING**
Scale: N.T.S.

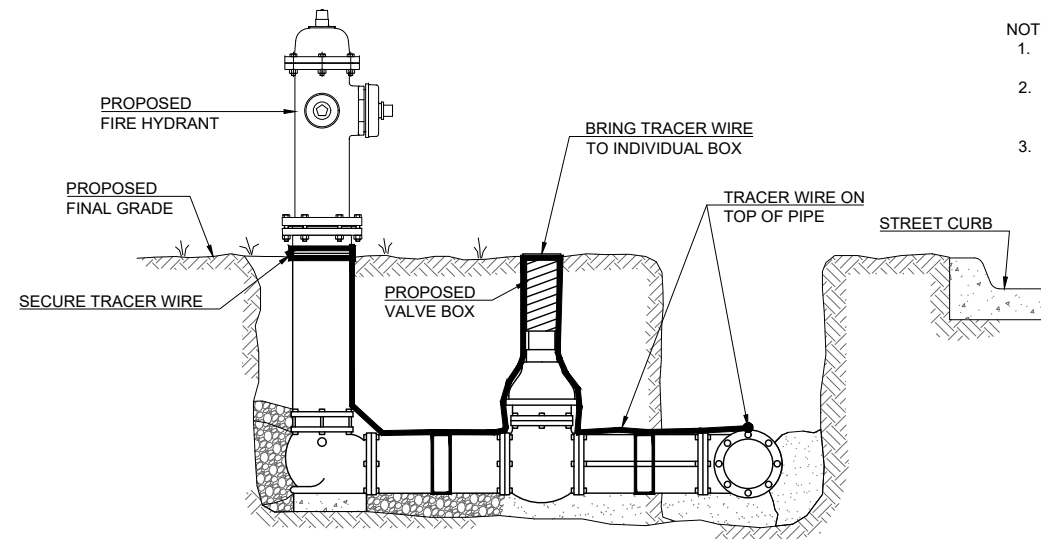

INSTALLATION OF TRACER WIRE FOR PROPOSED FIRE HYDRANT & VALVE

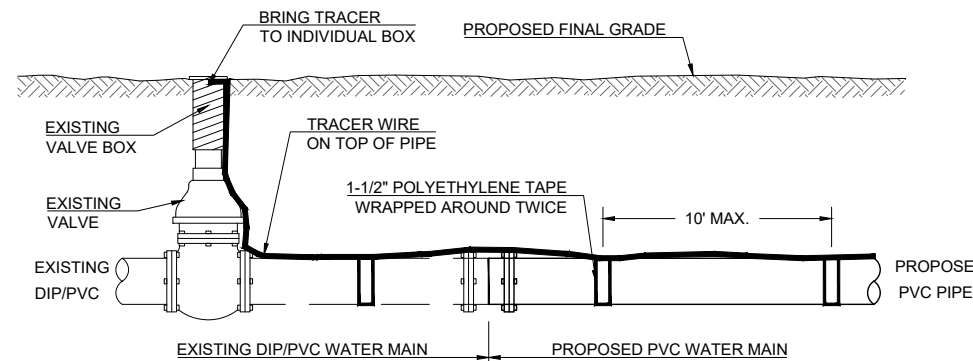

INSTALLATION OF TRACER WIRE FOR PROPOSED WATER VALVE & ALONG PVC WATER MAIN

NOTES:

1. ALL VALVES & VALVE BOXES ARE TO BE INSTALLED OUTSIDE EXISTING OR PROPOSED ADA RAMPS.
2. WHEN EXISTING DIP/PVC MAIN IS TO BE EXTENDED WITH A PVC MAIN, THE CONTRACTOR MUST EXCAVATE ALONG THE TOP OF EXISTING MAIN TO THE NEAREST EXISTING VALVE AND INSTALL A TRACER WIRE ON TOP OF EXISTING PIPE, AS SHOWN IN DETAIL.
3. TRACER WIRE MUST HAVE THERMOPLASTIC INSULATION/NYLON SHEATH. ABRASION, HEAT, MOISTURE, OIL & GASOLINE RESISTANT

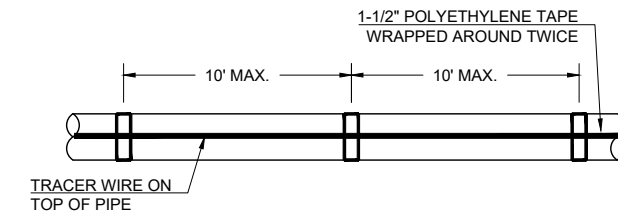

INSTALLATION OF TRACER WIRE ALONG TOP OF PVC WATER MAIN

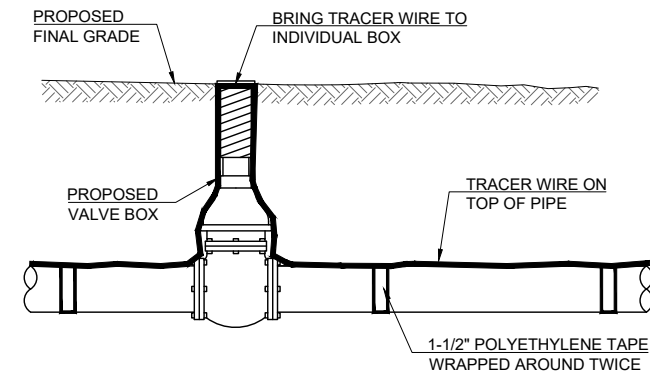

INSTALLATION OF TRACER WIRE FOR PROPOSED PVC WATER MAIN WITH CONNECTION TO EXISTING DIP/PVC WATER MAIN

01
515 **PVC PIPE TRACER WIRE INSTALLATION**
Scale: N.T.S.

APPROVED BY: *Will Huggins*
DEBORAH K. WILLIAMS, P.E., INTERMEDIATE CITY ENGINEER
CHRIS BROWNING, GENERAL MANAGER
WILL HUGGINS, P.E., DEPUTY DIRECTOR UTILITIES ENGINEERING

DATE: 10/16/2023
DATE: 10/10/2023
DATE: 10/10/2023

WATER STANDARD DETAILS
WATER MISCELLANEOUS
DETAILS 505.01, 515.01 AND 518.01

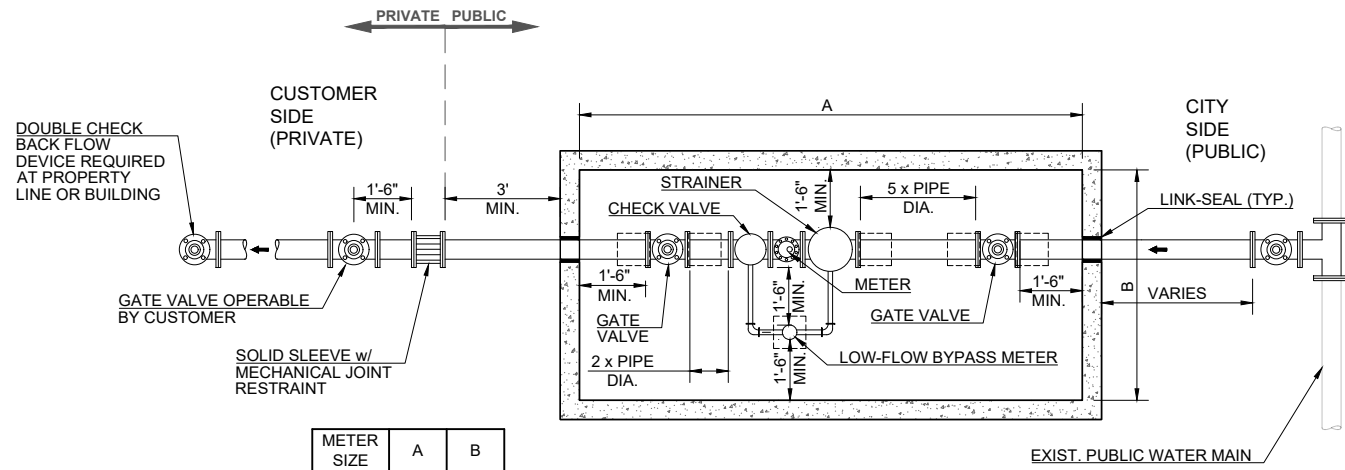

METER SIZE	A	B
6"	13'-0"	6'-0"
8"	13'-0"	6'-0"
10"	16'-6"	8'-6"
12"	18'-0"	9'-0"

01
506 **FIRE ASSEMBLY METER VAULT LAYOUT**
Scale: N.T.S.

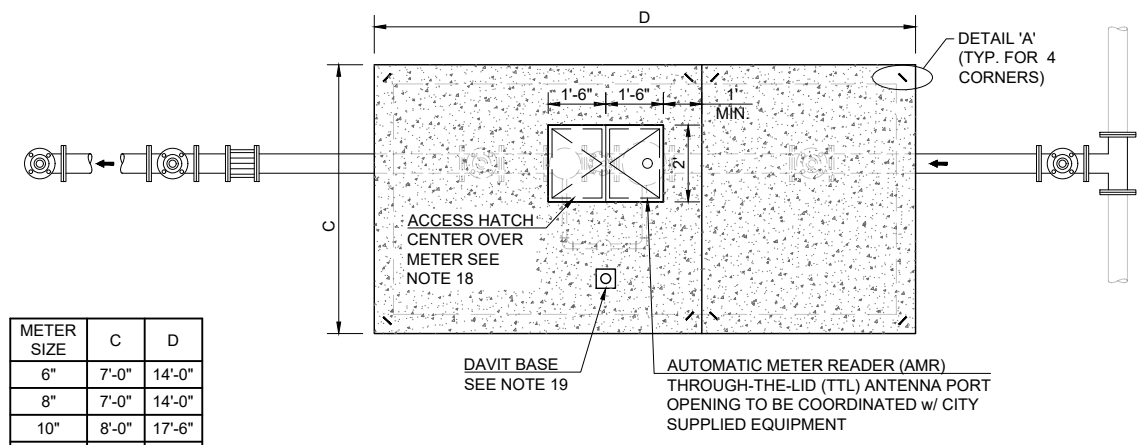

METER SIZE	C	D
6"	7'-0"	14'-0"
8"	7'-0"	14'-0"
10"	8'-0"	17'-6"
12"	9'-6"	19'-0"

02
506 **FIRE ASSEMBLY METER VAULT LID LAYOUT**
Scale: N.T.S.

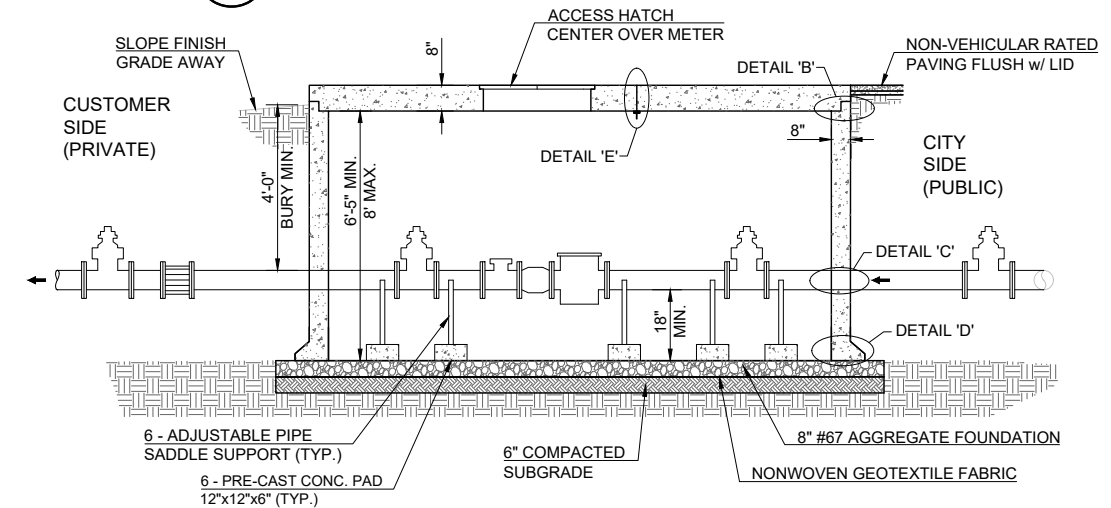

03
506 **FIRE ASSEMBLY METER VAULT**
Scale: N.T.S.

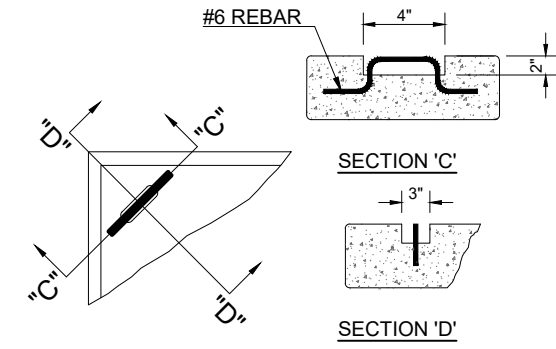

NOTE:
1. PROVIDE LIFTING EYES (4" MIN. PER PRECAST SECTION) BASED ON MIN. CAPACITY OF 2 TON / LIFTING EYE.

**LIFTING EYE DETAIL
DETAIL 'A'**

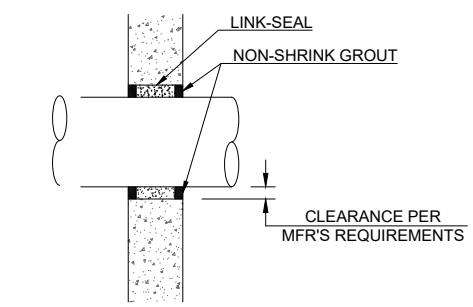

**SEAL & GROUT
PIPE WALL PENETRATION DETAIL
DETAIL 'C'**

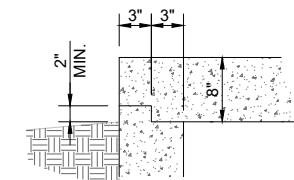

**PRECAST JOINT DETAIL
DETAIL 'B'**

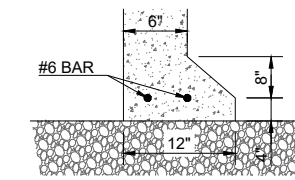

**FOOTING DETAIL
DETAIL 'D'**

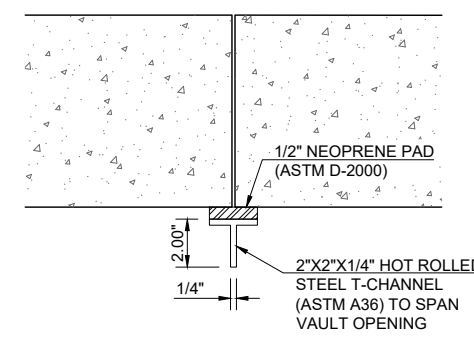

**STEEL CHANNEL CONNECTION DETAIL
DETAIL 'E'**

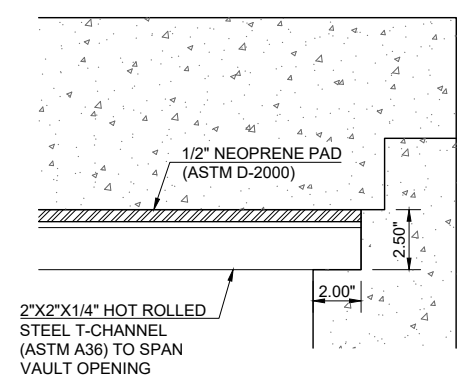

**STEEL CHANNEL CONNECTION DETAIL
(ROTATED 90 DEG.)
DETAIL 'F'**

GENERAL NOTES:

- ALL CONSTRUCTION MUST BE DONE IN STRICT ACCORDANCE WITH OKLAHOMA CITY'S "STANDARD SPECIFICATIONS FOR CONSTRUCTION OF PUBLIC IMPROVEMENTS" AND MUST BE UNDER THE STRICT SUPERVISION OF THE CITY ENGINEER OF THE CITY OF OKLAHOMA CITY.
- FOR VAULTS LOCATED WITHIN VEHICULAR TRAVELLED SURFACES, THE VAULT MUST BE DESIGNED FOR THE PROPER VEHICLE LOADING CONDITIONS. HALLIDAY VAULTS IN GRASS AREA AND EJ DUCTILE FOR PAVING AREA. HEAVY DUTY FRAME AND COVER w/ SAFETY FALL GRATING.
- VAULT ACCESS HATCHES OUTSIDE VEHICULAR TRAVELLED SURFACES w/ SAFETY FALL GRATING.
- PRECAST VAULTS MUST BE CONSTRUCTED AS SPECIFIED IN ASTM C857-16 & ASTM C858-18.
- CONCRETE MUST HAVE A MIN. 7 DAY COMPRESSIVE STRENGTH OF 4000 PSI.
- REINFORCING STEEL MUST BE GRADE 60.
- REINFORCING STEEL MUST HAVE A MIN. 2" CLEAR SPACE FROM EXPOSED SURFACE.
- MINIMUM REINFORCEMENT IN VAULT LID & WALLS MUST BE GRADE 60, #3 BARS AT 9 1/2" CC EW OR GRADE 65 WIRE MESH W6.2 / W6.2, 6"x 6".
- JOINTS BETWEEN PRECAST VAULT SECTIONS (LID TO WALL OR WALL TO WALL) MUST HAVE CONCRETE JOINT SEALANT APPLIED TO THE JOINT PRIOR TO THE SECTIONS BEING ASSEMBLED. SEALANT MUST MEET ASTM C990, U.S. FEDERAL SPECIFICATION SS-5-210A, TYPE 1, ROPE FORM & AASHTO M-198-10.
- SUBGRADE MUST BE COMPACTED TO 95% STD. PROCTOR DENSITY, ASTM D-698.
- GEOTEXTILE FABRIC MUST BE NON-WOVEN POLYPROPYLENE, TENSILE STRENGTH OF 200 LBS.
- AGGREGATE FOUNDATION MUST BE ASTM C-33 #67 COMPACTED TO 95% STD. PROCTOR DENSITY, ASTM D-698.
- PRECAST VAULTS MUST BE INSTALLED AS SPECIFIED IN ASTM C891-11.
- ALL FITTINGS WITHIN VAULT MUST BE FLANGED.
- ALL FITTINGS & PIPE OUTSIDE OF VAULT MUST BE RESTRAINED FITTINGS.
- ADJUSTABLE PIPE SADDLE SUPPORT w/ THREADED PIPE STAND w/ ELECTRO-GALVANIZED FINISH MEETING ANSI / MSS SP-69 & SP-58, TYPE 38.
- ALL PIPE & FITTINGS WITHIN THE VAULT MUST BE DUCTILE IRON PIPE (DIP). DIP MUST EXTEND A MINIMUM OF 3' BEYOND THE OUTSIDE FACE OF THE VAULT. WHERE CONNECTING TO PVC PIPE OUTSIDE OF THE VAULT A MECHANICALLY RESTRAINED SOLID SLEEVE OR FITTING MUST BE USED.
- ACCESS HATCH MUST BE HALLIDAY PRODUCTS SERIES H2R ACCESS DOOR, OR APPROVED EQUAL.
- CONTRACTOR MUST INSTALL A 3M DBI-SALA FLOOR MOUNT CAST-IN-PLACE SLEEVE DAVIT BASE, OR APPROVED EQUAL, WITHIN THE VAULT LID. THIS DAVIT BASE MUST BE INSTALLED 2 FEET FROM ACCESS HATCHES TO ALLOW PORTABLE HOIST SYSTEM TO BE USED. THIS SYSTEM MUST BE INSTALLED IN A MANNER THAT DOES NOT INTERFERE WITH ACCESS TO HATCH.

APPROVED BY: *Deborah N. Miller*
DEBORAH N. MILLER, P.E., INTEGRITY CITY ENGINEER
DATE: 10/16/2023
Chris Browning
CHRIS BROWNING, GENERAL MANAGER
DATE: 10/10/2023
Will Huggins
WILL HUGGINS, P.E., DEPUTY DIRECTOR
UTILITIES ENGINEERING
DATE: 10/10/2023

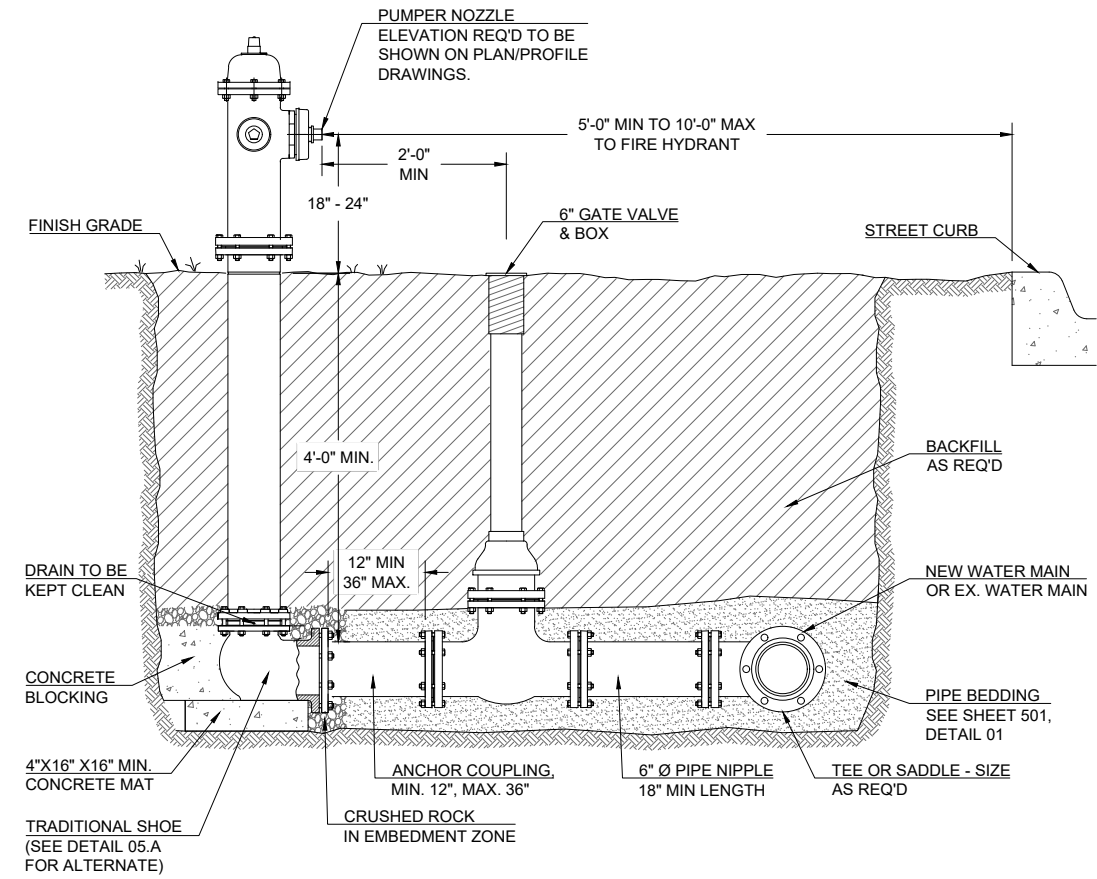
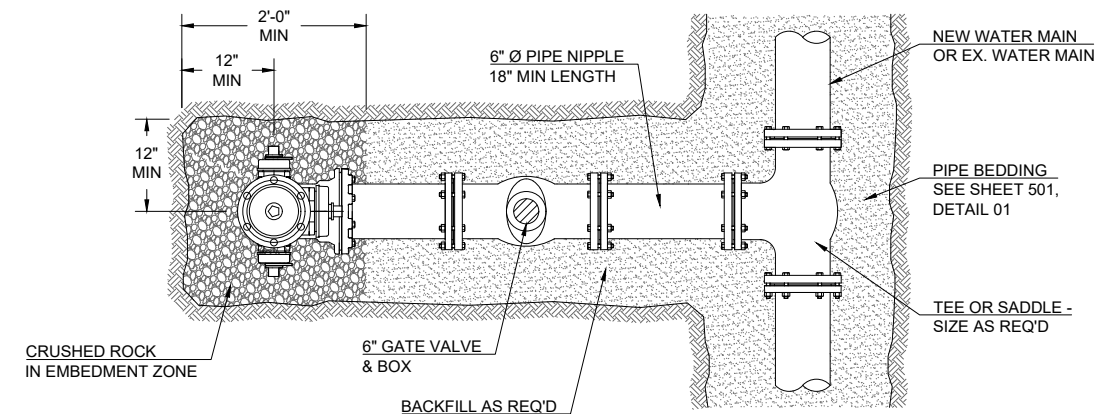
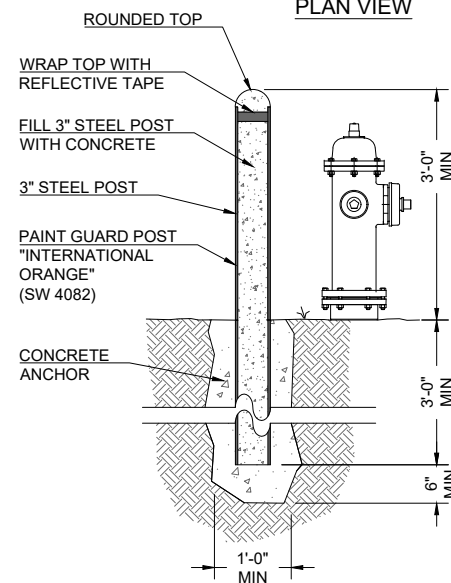
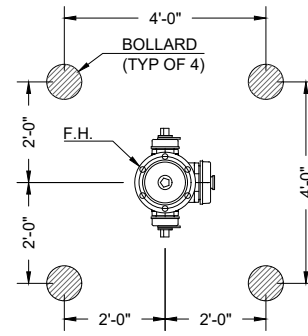
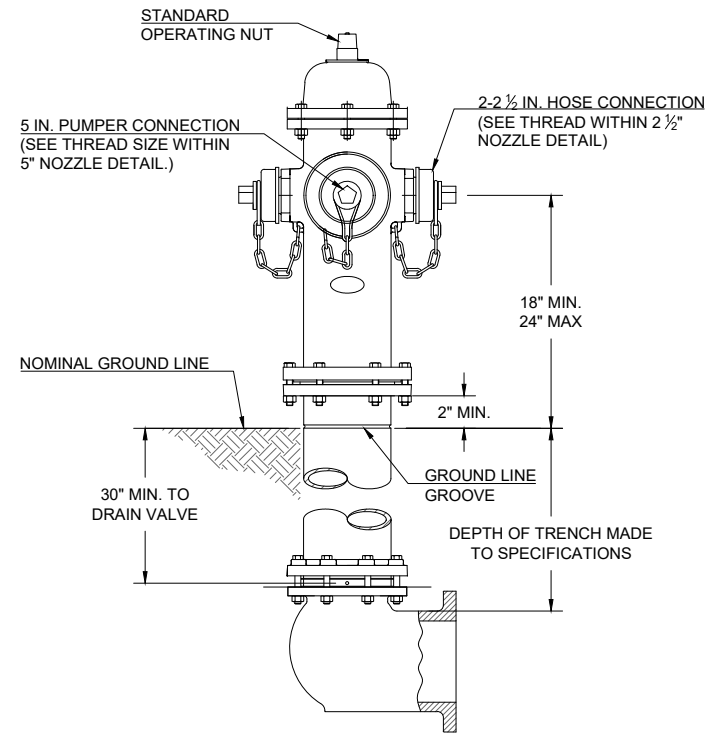

- NOTES:
1. FIRE HYDRANTS MUST BE INSTALLED IN TRUE VERTICAL POSITION.
 2. HYDRANT COLOR IS AS FOLLOWS:
A.) FOR PUBLIC: INTERNATIONAL ORANGE (SW 4082)
B.) FOR PRIVATE: CANARY YELLOW (FFEF00)
 3. THRUST RESTRAINTS TO BE USED.
 4. ALL VALVES & VALVE BOXES ARE TO BE INSTALLED OUTSIDE EXISTING OR PROPOSED ADA RAMPS AND SIDEWALKS.
 5. FIRE HYDRANTS ARE ONLY AUTHORIZED TO HAVE 1-12 INCH EXTENSION AND ALL PARTS ARE TO BE ORIGINAL EQUIPMENT MANUFACTURER. OTHERWISE A VERTICAL SHOE MUST BE UTILIZED.

01 FIRE HYDRANT
507 Scale: N.T.S.

02 BOLLARD INSTALLATION
507 Scale: N.T.S.

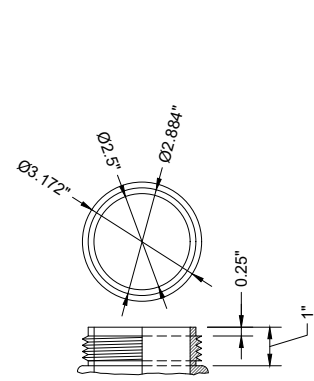

2.5" NOZZLE

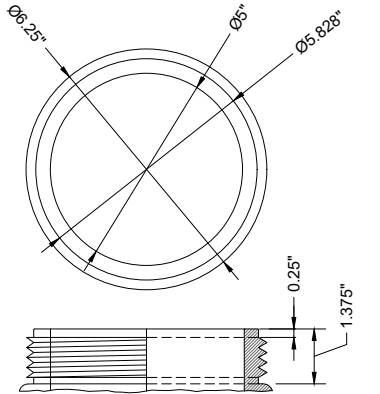

5" NOZZLE

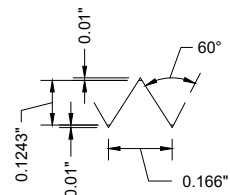

FORM OF THREAD
CLEARANCE BETWEEN MALE AND FEMALE THREAD .03", 6 THREADS PER INCH. PITCH DIAMETER 3.028" MAXIMUM VARIATION 0.005".

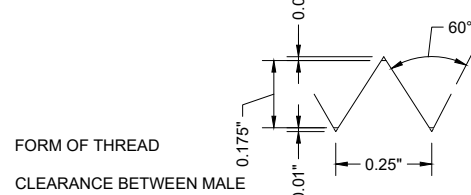

FORM OF THREAD
CLEARANCE BETWEEN MALE AND FEMALE THREAD .05" 4 THREADS PER INCH. PITCH DIAMETER 6.033" MAXIMUM VARIATION 0.009".

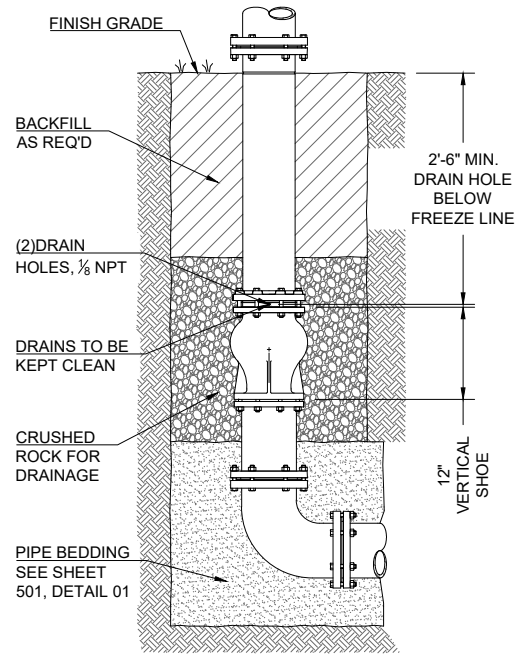

05.A (ALT.) VERTICAL SHOE
507 Scale: N.T.S.

03 FIRE HYDRANT 2.5" NOZZLE DETAIL
507 Scale: N.T.S.

04 FIRE HYDRANT 5.0" NOZZLE DETAIL
507 Scale: N.T.S.

05 FIRE HYDRANT CONNECTION TO MAIN
507 Scale: N.T.S.

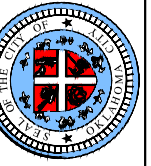

APPROVED BY: *Chris Browning* DATE: 10/16/2023
DEPUTY CITY ENGINEER
Chris Browning DATE: 10/10/2023
GENERAL MANAGER
Will Higgins DATE: 10/10/2023
DEPUTY DIRECTOR
UTILITIES ENGINEERING

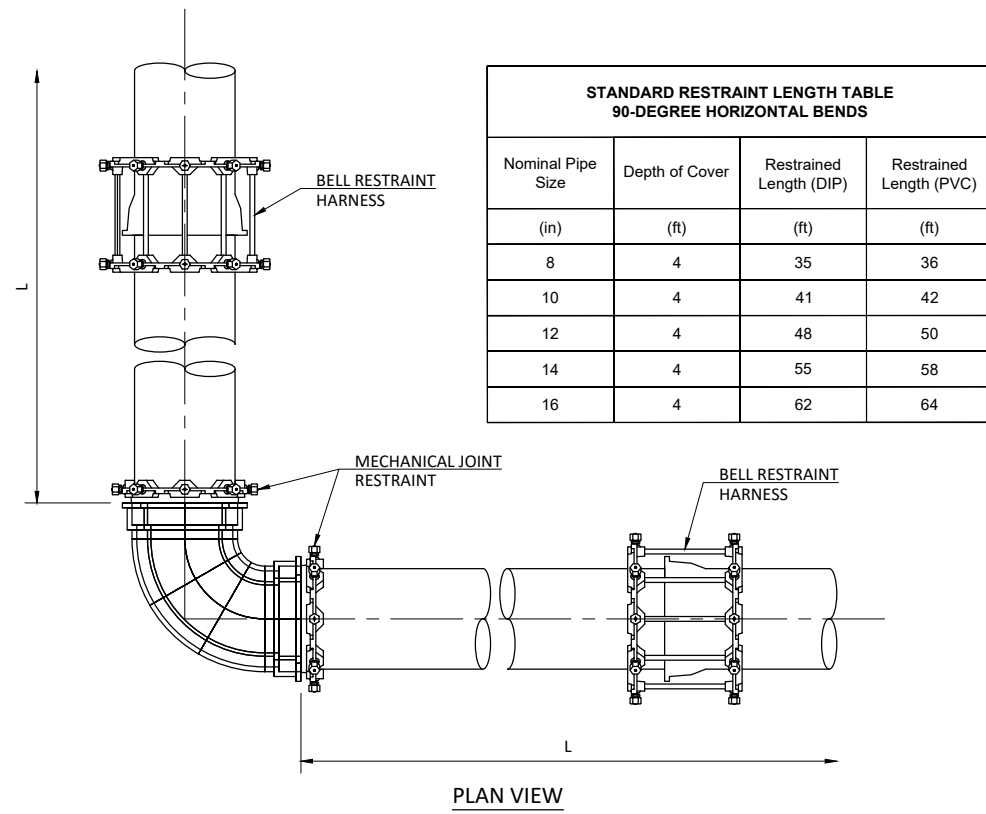

STANDARD RESTRAINT LENGTH TABLE 90-DEGREE HORIZONTAL BENDS			
Nominal Pipe Size	Depth of Cover	Restrained Length (DIP)	Restrained Length (PVC)
(in)	(ft)	(ft)	(ft)
8	4	35	36
10	4	41	42
12	4	48	50
14	4	55	58
16	4	62	64

01
509
RESTRAINING 90° BEND
Scale: N.T.S.

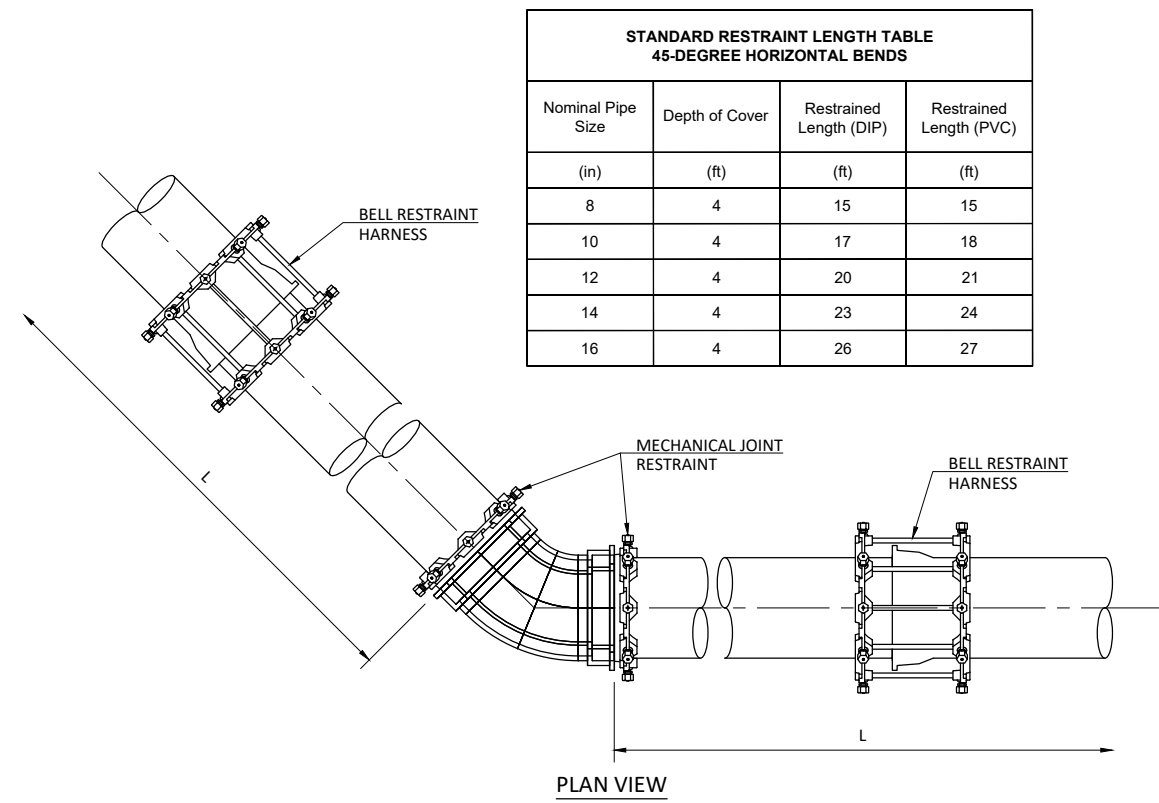

STANDARD RESTRAINT LENGTH TABLE 45-DEGREE HORIZONTAL BENDS			
Nominal Pipe Size	Depth of Cover	Restrained Length (DIP)	Restrained Length (PVC)
(in)	(ft)	(ft)	(ft)
8	4	15	15
10	4	17	18
12	4	20	21
14	4	23	24
16	4	26	27

02
509
RESTRAINING 45° BEND
Scale: N.T.S.

GENERAL NOTES
1. CONTRACTOR TO FOLLOW ALL MANUFACTURERS SPECIFICATIONS FOR INSTALLATION OF MECHANICAL JOINT RESTRAINTS AND BELL RESTRAINT HARNESSSES.

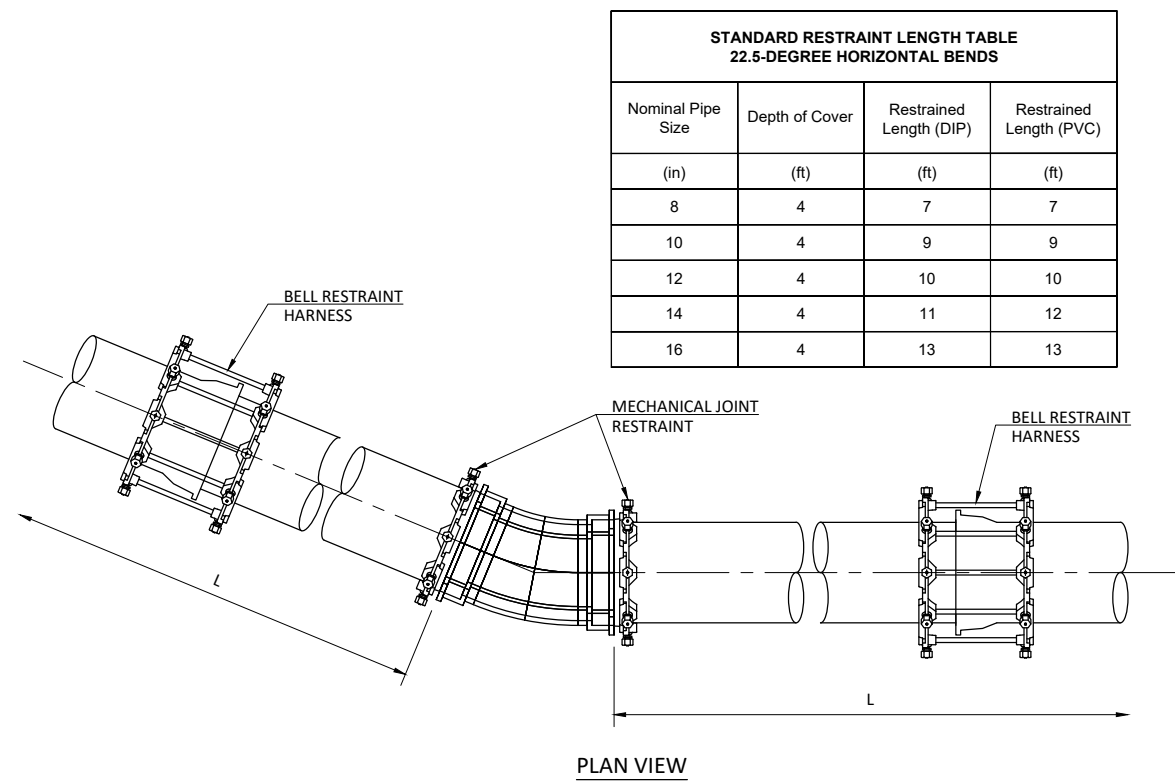

STANDARD RESTRAINT LENGTH TABLE 22.5-DEGREE HORIZONTAL BENDS			
Nominal Pipe Size	Depth of Cover	Restrained Length (DIP)	Restrained Length (PVC)
(in)	(ft)	(ft)	(ft)
8	4	7	7
10	4	9	9
12	4	10	10
14	4	11	12
16	4	13	13

03
509
RESTRAINING 22 1/2° BEND
Scale: N.T.S.

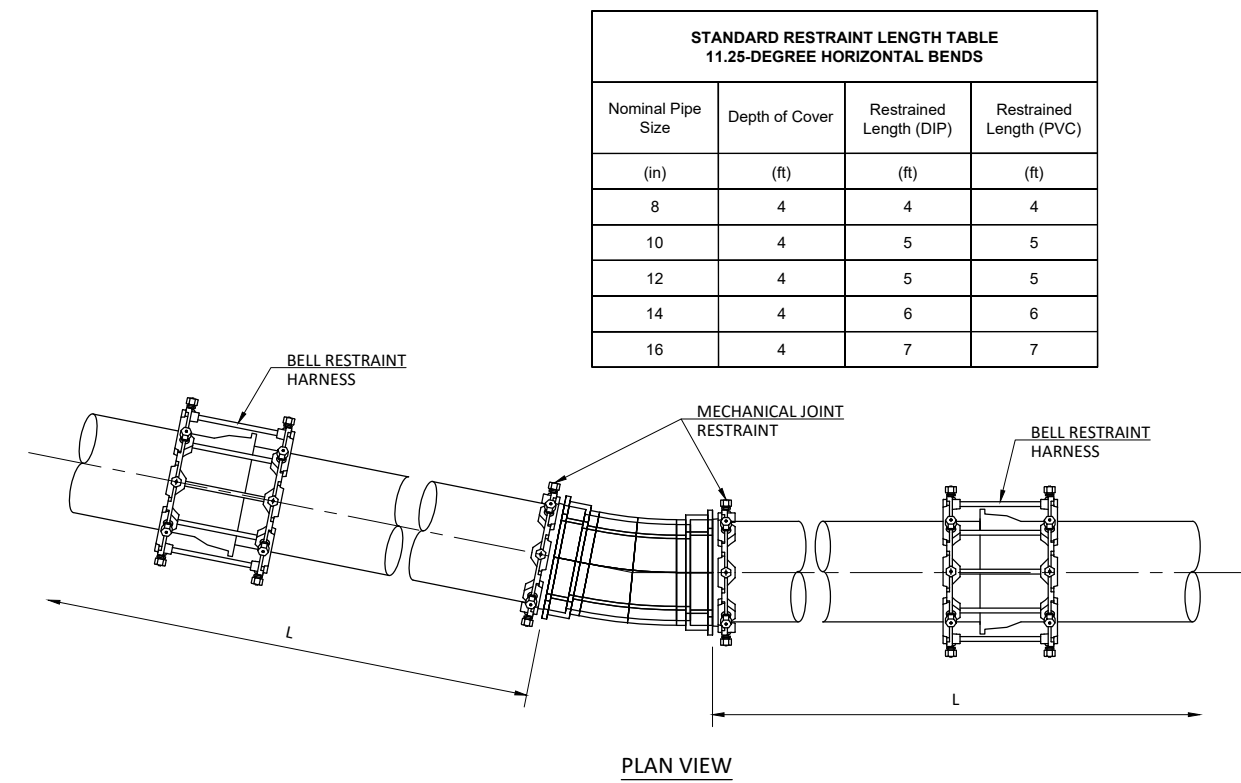

STANDARD RESTRAINT LENGTH TABLE 11.25-DEGREE HORIZONTAL BENDS			
Nominal Pipe Size	Depth of Cover	Restrained Length (DIP)	Restrained Length (PVC)
(in)	(ft)	(ft)	(ft)
8	4	4	4
10	4	5	5
12	4	5	5
14	4	6	6
16	4	7	7

04
509
RESTRAINING 11 1/4° BEND
Scale: N.T.S.

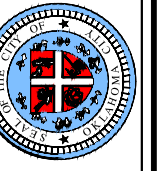

APPROVED BY:
DEBORAH K. MILLER, P.E., INTERIM CITY ENGINEER
CHRIS BROWNING, GENERAL MANAGER
WILL HUGGINS, P.E., DEPUTY DIRECTOR UTILITIES ENGINEERING
DATE: 10/16/2023
DATE: 10/10/2023
DATE: 10/10/2023

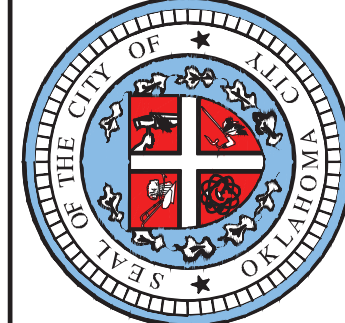

APPROVED BY:

 DEBORAH K. MILLER, P.E., CITY ENGINEER

 CHRIS BROWN, GENERAL MANAGER

 WILL HUGGINS, P.E., DEPUTY DIRECTOR
 UTILITIES ENGINEERING

WATER STANDARD DETAILS
 THRUST RESTRAINTS
 DETAILS 509.05 TO 509.08

509.B

**STANDARD RESTRAINT LENGTH TABLE
TEES**

Nominal Size of Run	Nominal Branch Size	Depth of Cover	Restrained Length (DIP) (2)	Restrained Length (PVC) (2)
(in)	(in)	(ft)	(ft)	(ft)
8	8	4	L = 89 - (4.80 * Lu)	L = 97 - (5.21 * Lu)
10	10	4	L = 107 - (4.84 * Lu)	L = 117 - (5.27 * Lu)
12	12	4	L = 126 - (4.88 * Lu)	L = 138 - (5.31 * Lu)
14	14	4	L = 144 - (4.93 * Lu)	L = 161 - (5.33 * Lu)
16	16	4	L = 163 - (4.94 * Lu)	L = 178 - (5.40 * Lu)

**STANDARD RESTRAINT LENGTH TABLE
REDUCERS**

Nominal Pipe Size	Minimum Nominal Size of Reducer	Depth of Cover	Restrained Length (DIP)	Restrained Length (PVC)
(in)	(in)	(ft)	(ft)	(ft)
8	6	4	38	41
10	8	4	36	39
12	8	4	67	73
14	12	4	37	41
16	12	4	69	75

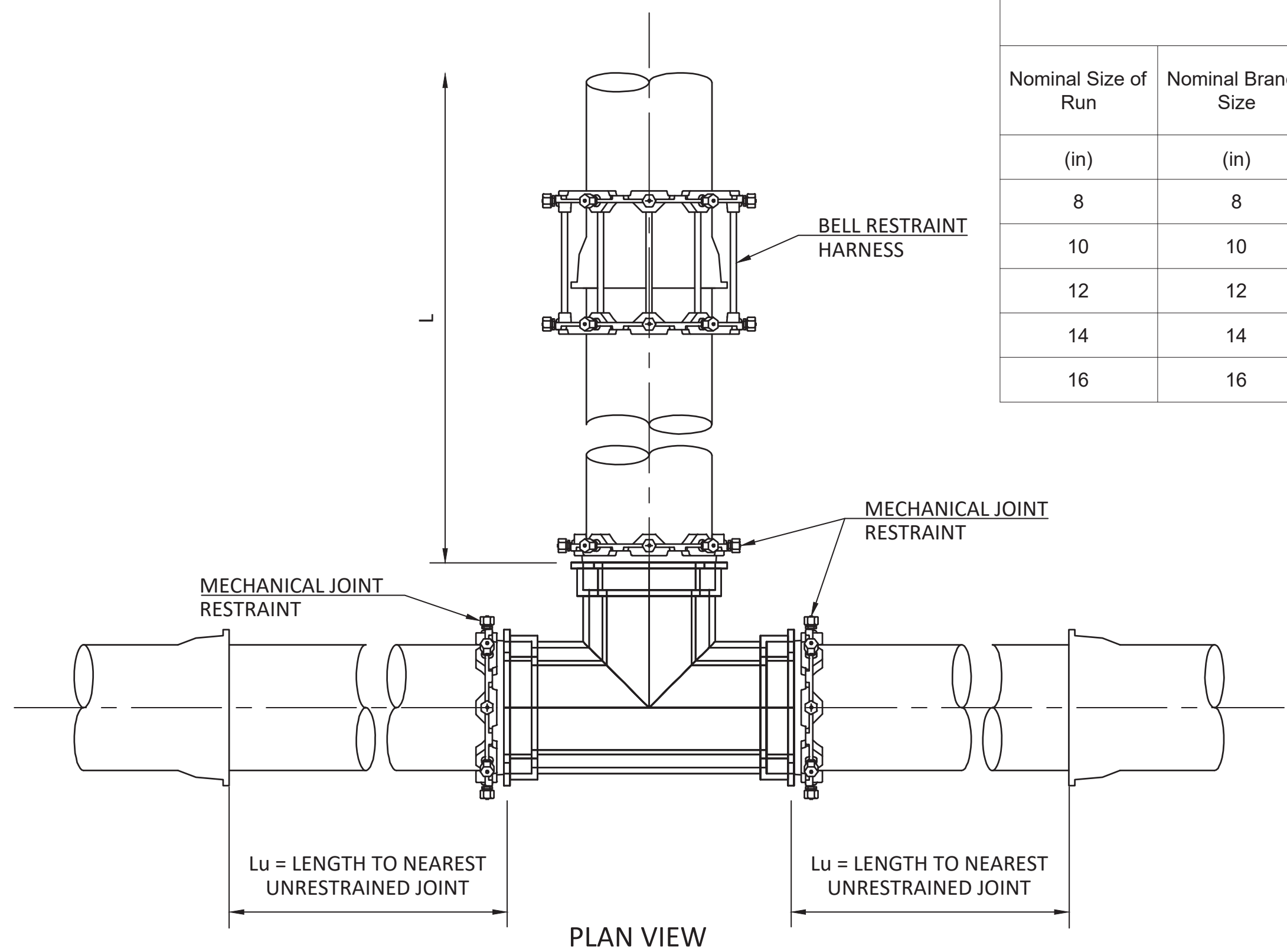

05
509
RESTRAINING TEE BEND
Scale: N.T.S.

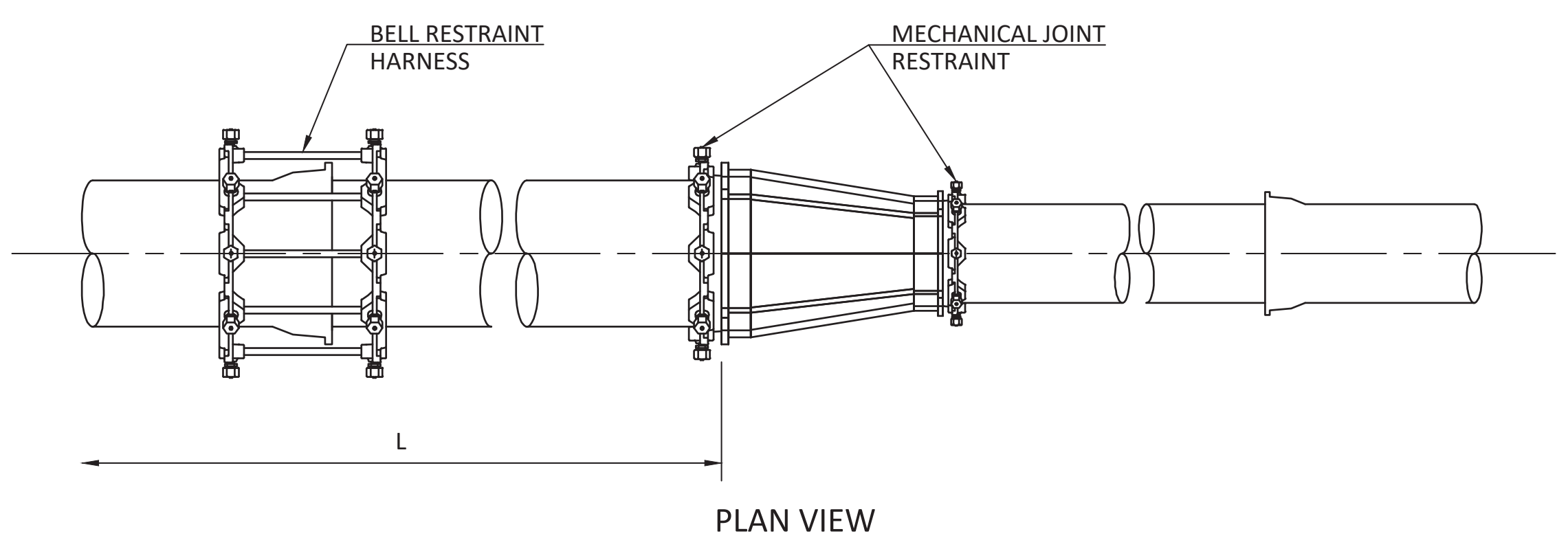

06
509
RESTRAINING REDUCER FITTING
Scale: N.T.S.

- GENERAL NOTES**
- CONTRACTOR TO FOLLOW ALL MANUFACTURERS SPECIFICATIONS FOR INSTALLATION OF MECHANICAL JOINT RESTRAINTS AND BELL RESTRAINT HARNESES
 - IF CALCULATION YIELDS NEGATIVE VALUE, NO RESTRAINED LENGTH IS REQUIRED ALONG THE BRANCH

**STANDARD RESTRAINT LENGTH TABLE
VALVES**

Nominal Pipe Size	Depth of Cover	Restrained Length (DIP)	Restrained Length (PVC)
(in)	(ft)	(ft)	(ft)
8	4	89	97
10	4	107	116
12	4	126	137
14	4	144	160
16	4	162	177

**STANDARD RESTRAINT LENGTH TABLE
VERTICAL OFFSET BENDS**

Nominal Pipe Size	Angle of Bend	Depth of Cover (Upper)	Depth of Cover (Lower)	Restrained Length L _A (Upper) (DIP)	Restrained Length L _B (Lower) (DIP)	Restrained Length L _A (Upper) (PVC)	Restrained Length L _B (Lower) (PVC)
(in)	(degrees)	(ft)	(ft)	(ft)	(ft)	(ft)	(ft)
8	45	4	8	37	8	40	8
10	45	4	8	45	9	48	10
12	45	4	8	52	11	57	11
14	45	4	8	60	12	67	13
16	45	4	8	67	14	74	14

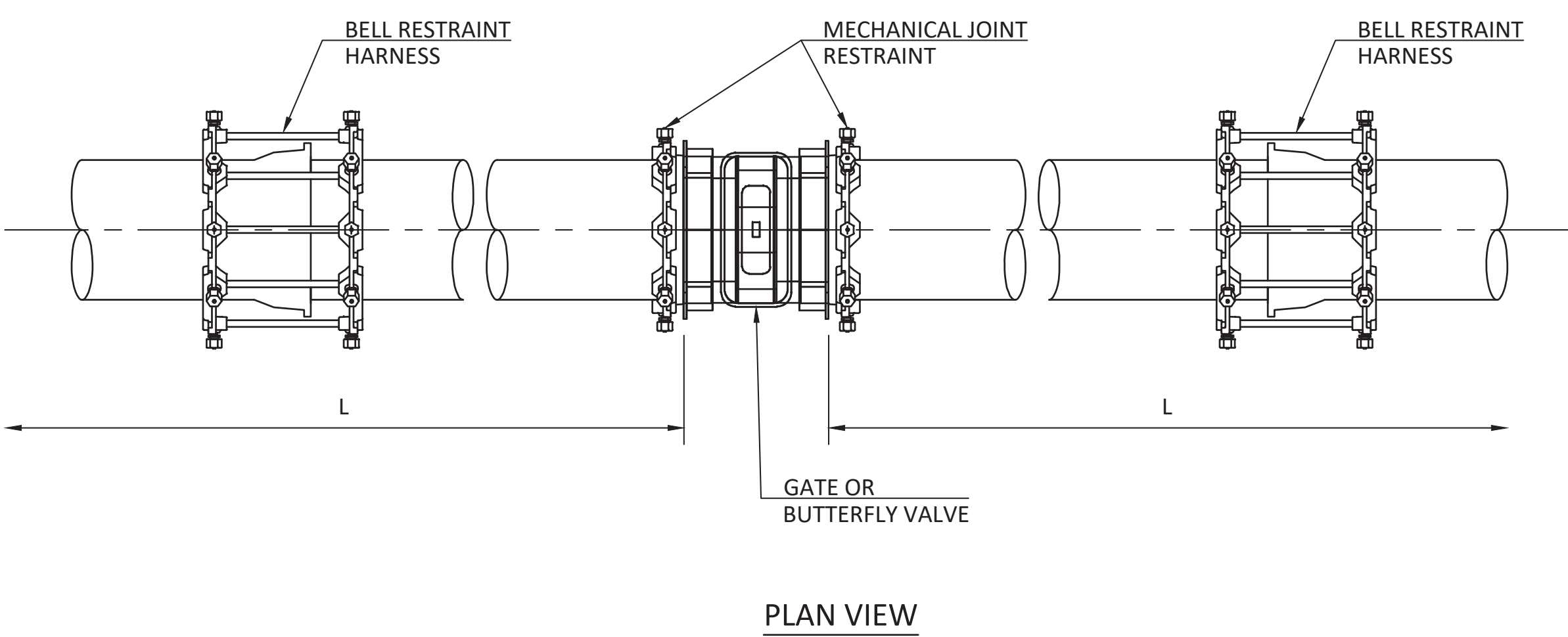

07
509
RESTRAINING VALVE CONNECTION
Scale: N.T.S.

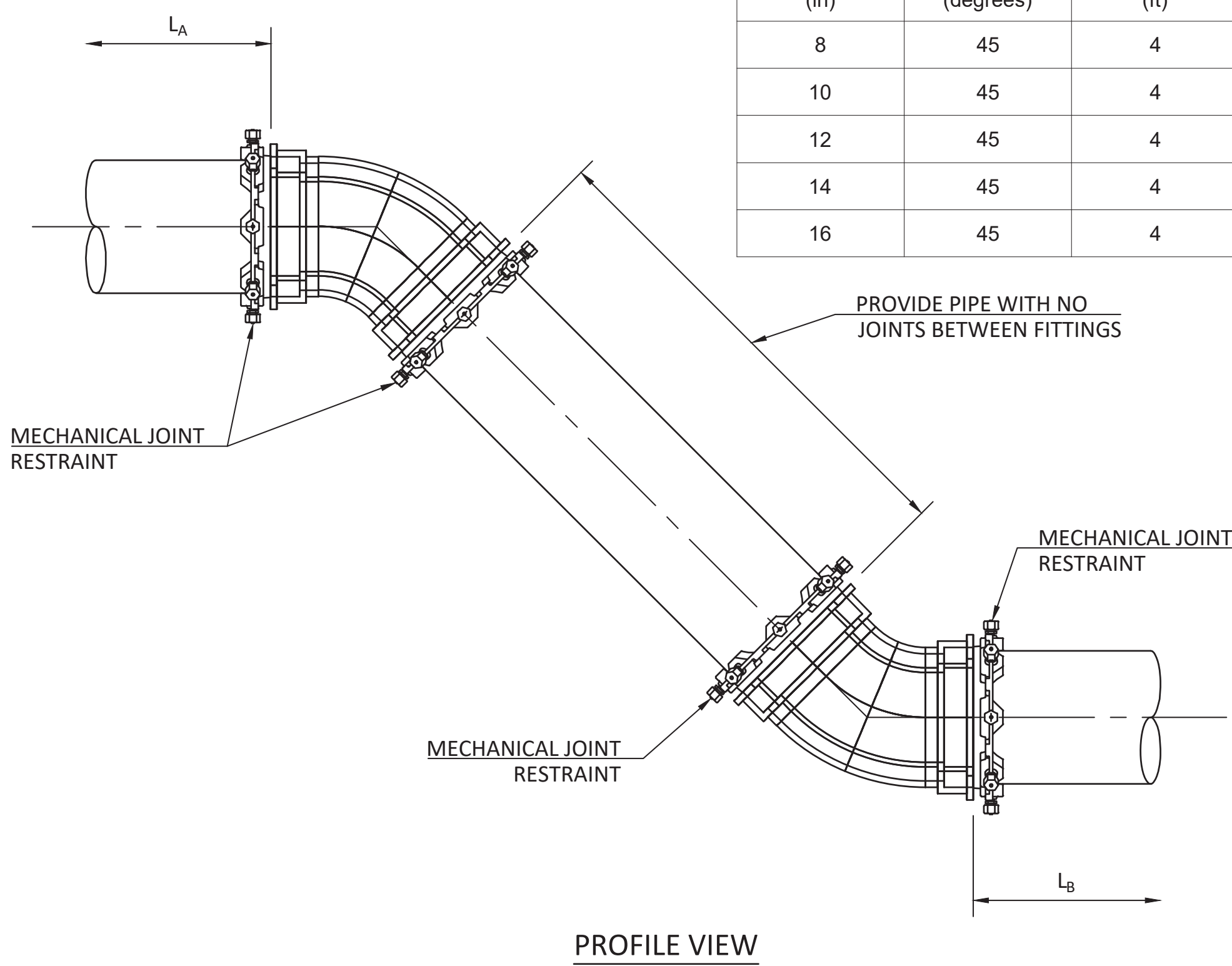

08
509
RESTRAINING HORIZONTAL OR VERTICAL OFFSET
Scale: N.T.S.

NOTE: 2'x 2'x 6" CONCRETE PAD REQUIRED FOR ALL SURFACES ALL VALVES. NO PRECAST CONCRETE DONUTS ALLOWED.

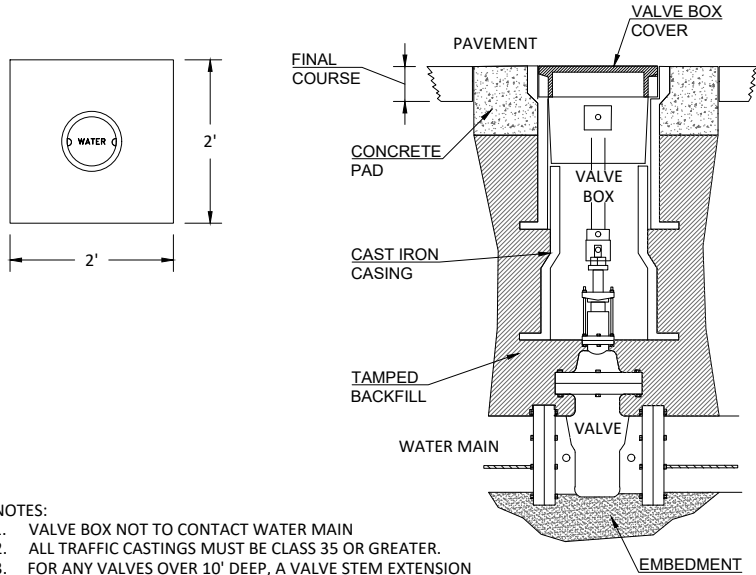

- NOTES:
1. VALVE BOX NOT TO CONTACT WATER MAIN
 2. ALL TRAFFIC CASTINGS MUST BE CLASS 35 OR GREATER.
 3. FOR ANY VALVES OVER 10' DEEP, A VALVE STEM EXTENSION MUST BE USED TO BRING TO A DEPTH OF NO MORE THAN 5', EXTENSION MUST BE A MINIMUM OF 1" SOLID STOCK.
 4. TOTAL VALVE BOX WEIGHT: MINIMUM OF 85 LBS.

01 VALVE AND VALVE BOX
512 Scale: N.T.S.

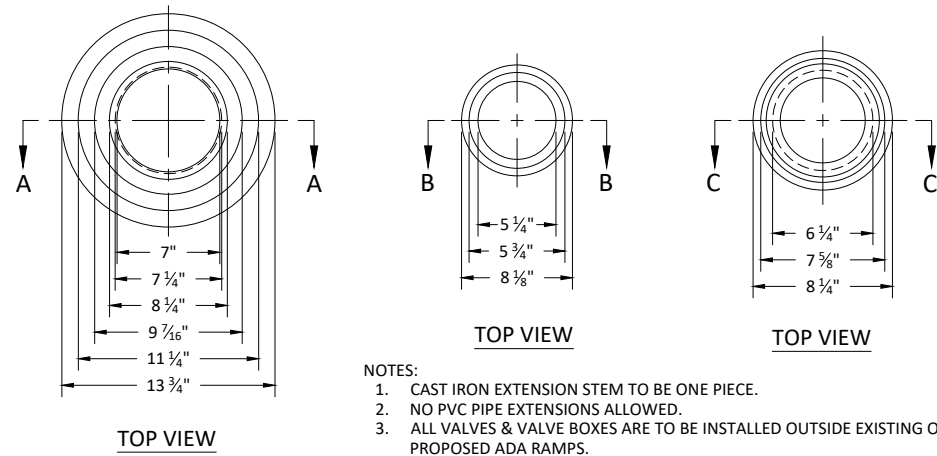

- NOTES:
1. CAST IRON EXTENSION STEM TO BE ONE PIECE.
 2. NO PVC PIPE EXTENSIONS ALLOWED.
 3. ALL VALVES & VALVE BOXES ARE TO BE INSTALLED OUTSIDE EXISTING OR PROPOSED ADA RAMP.

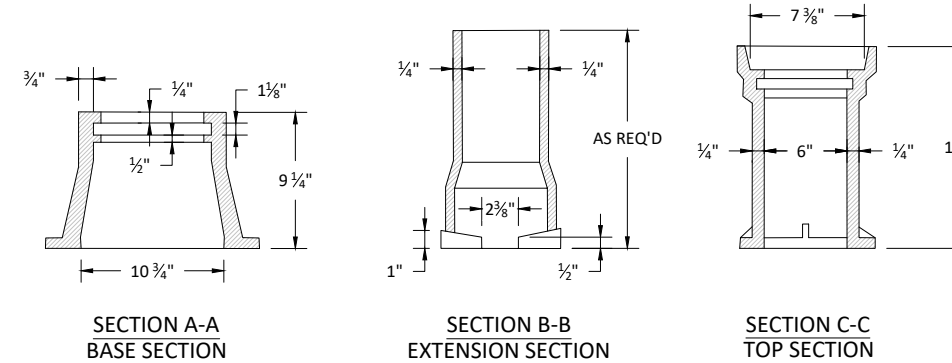

02 CAST IRON VALVE BOX
512 Scale: N.T.S.

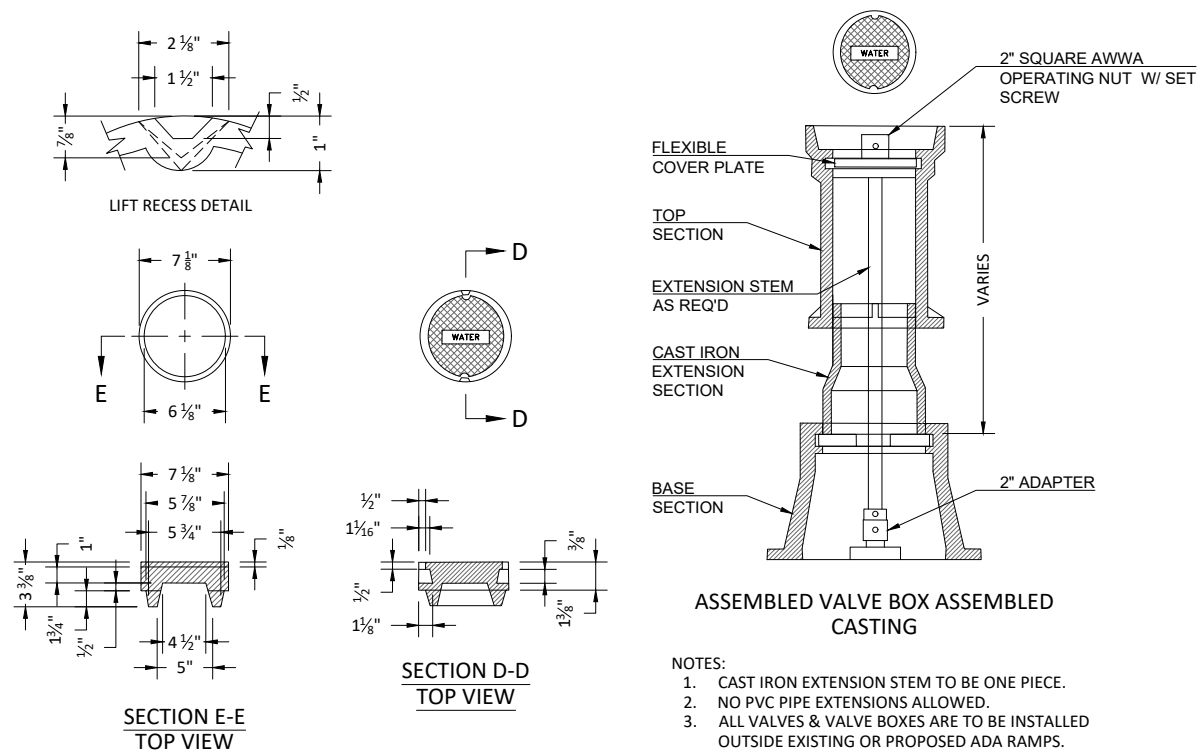

- NOTES:
1. CAST IRON EXTENSION STEM TO BE ONE PIECE.
 2. NO PVC PIPE EXTENSIONS ALLOWED.
 3. ALL VALVES & VALVE BOXES ARE TO BE INSTALLED OUTSIDE EXISTING OR PROPOSED ADA RAMP.

03 CAST IRON VALVE BOX
512 Scale: N.T.S.

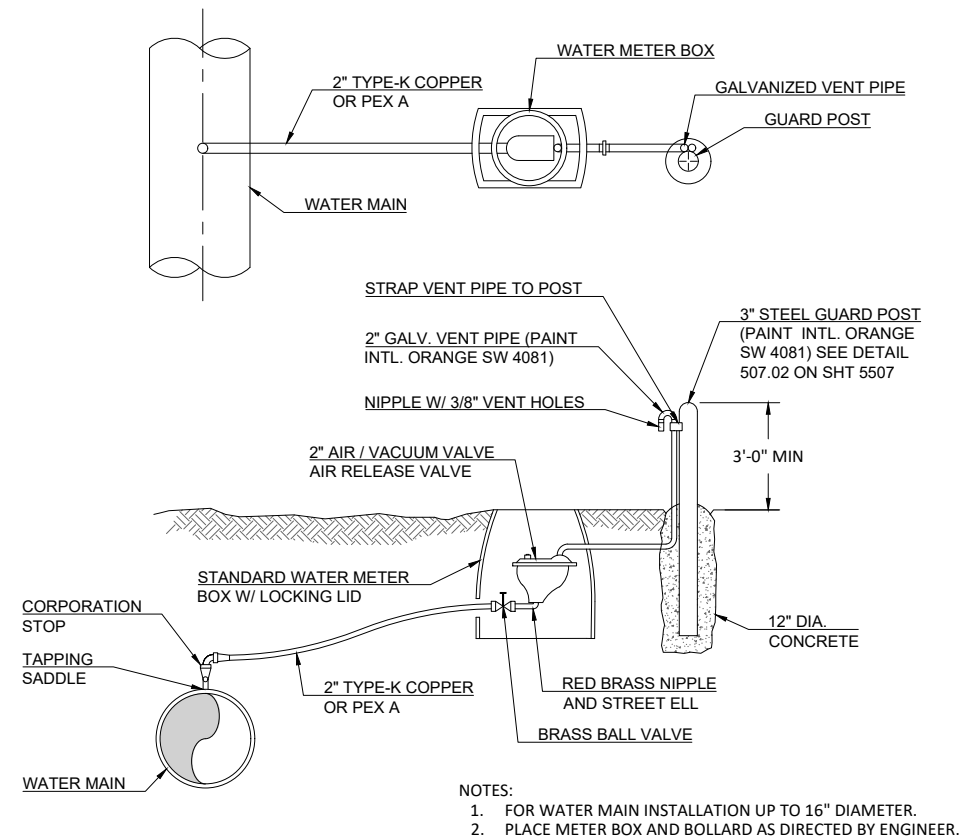

- NOTES:
1. FOR WATER MAIN INSTALLATION UP TO 16" DIAMETER.
 2. PLACE METER BOX AND BOLLARD AS DIRECTED BY ENGINEER.

04 2 INCH AIR RELEASE VALVE AND VALVE BOX
512 Scale: N.T.S.

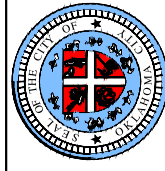

APPROVED BY: *Chris Browning*
DATE: 10/16/2023
DESIGNED BY: *Will Huggins*
DATE: 10/10/2023
CHECKED BY: *Chris Browning*
DATE: 10/10/2023
WILL HUGGINS, P.E. DEPUTY DIRECTOR
UTILITIES ENGINEERING

WATER STANDARD DETAILS
VALVE BOX
DETAILS 512.01 TO 512.04

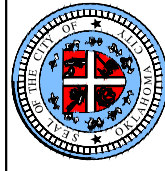

APPROVED BY:
DEBORAH K. MILLER, P.E., INTERIM CITY ENGINEER
CHRIS BROWNING, GENERAL MANAGER
WILL HUGGINS, P.E., DEPUTY DIRECTOR
UTILITIES ENGINEERING

DATE: 10/16/2023
DATE: 10/10/2023
DATE: 10/10/2023

WATER STANDARD DETAILS
VALVE VAULT
DETAILS 512.05 TO 512.07

512.B

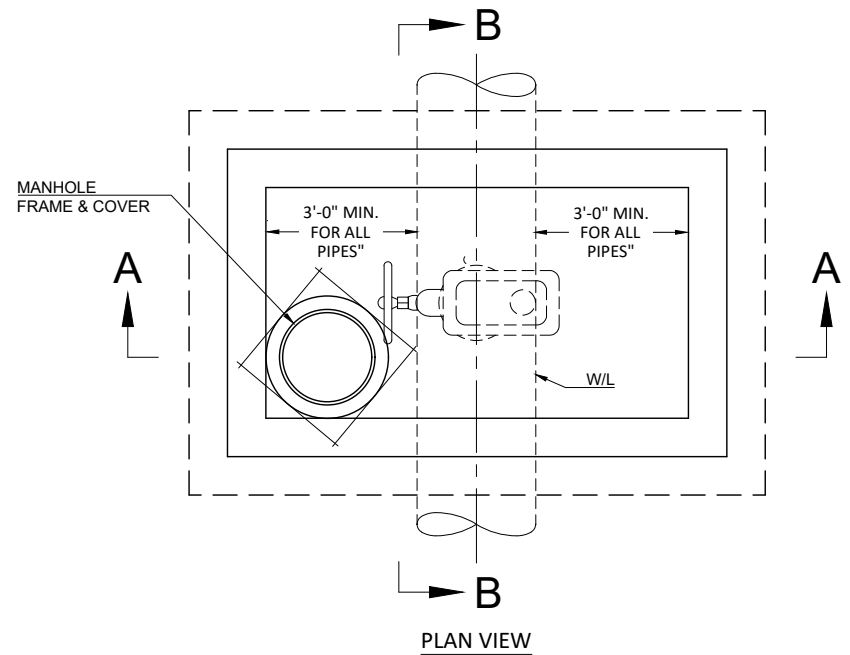

- NOTES:
1. VAULT TO BE STRUCTURAL DESIGNED BY ENGINEER.
 2. VAULT MUST BE OUTSIDE PAVEMENT.
 3. ALL MANHOLE LIDS, RINGS AND 4" VENT PIPE TO BE PAINTED INTL. ORANGE.
 4. ALL MANHOLE FRAMES, COVERS & REMOVABLE SECTIONS MUST HAVE SEALER GASKETS.
 5. COMPACT BACKFILL TO 95% STANDARD PROCTOR DENSITY IN 6 INCH LIFTS BY POWER TAMPING.
 6. SLOPE FLOOR 1/4" PER 1' TOWARD SUMP

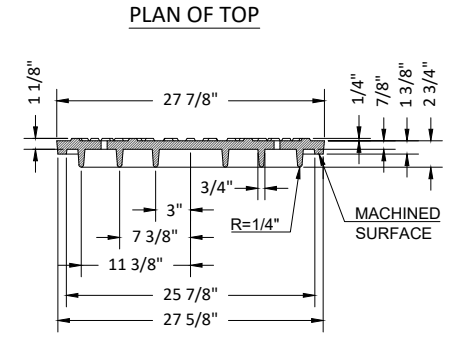
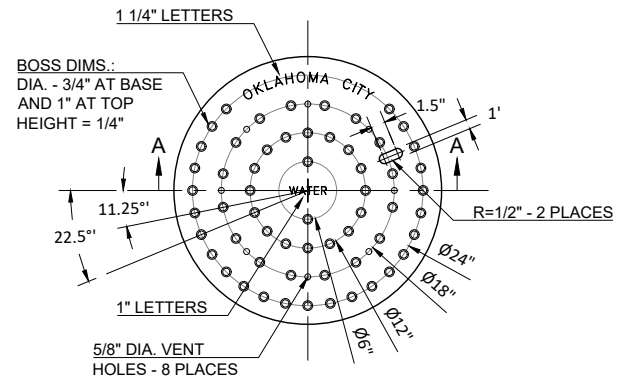

06 WATER MANHOLE COVER
Scale: N.T.S.

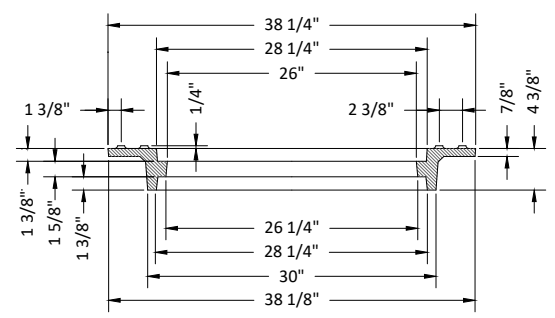
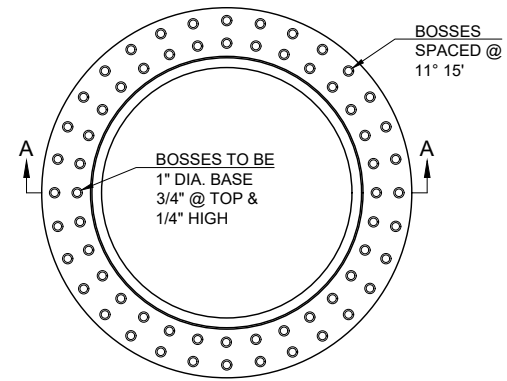

REVERSED FOR OUT OF PAVING INSTALLATION - TYPE B
AS SHOWN FOR IN PAVING INSTALLATION - TYPE A

07 WATER MANHOLE REVERSIBLE FRAME
Scale: N.T.S.

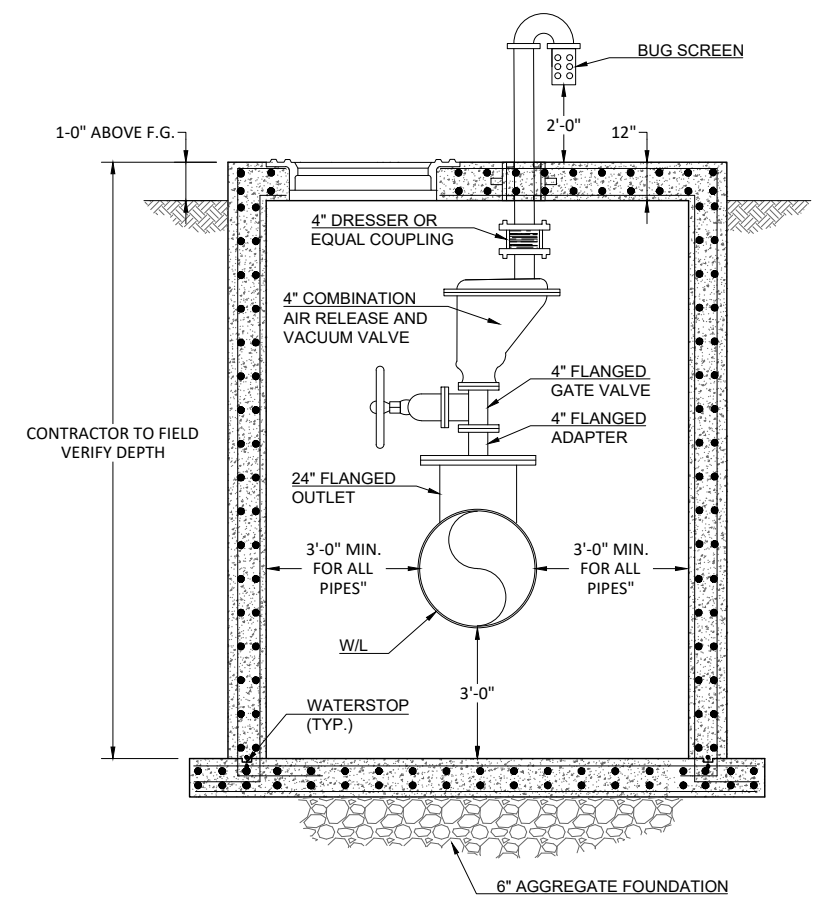

05 4 INCH AIR RELEASE VALVE AND VAULT
Scale: N.T.S.

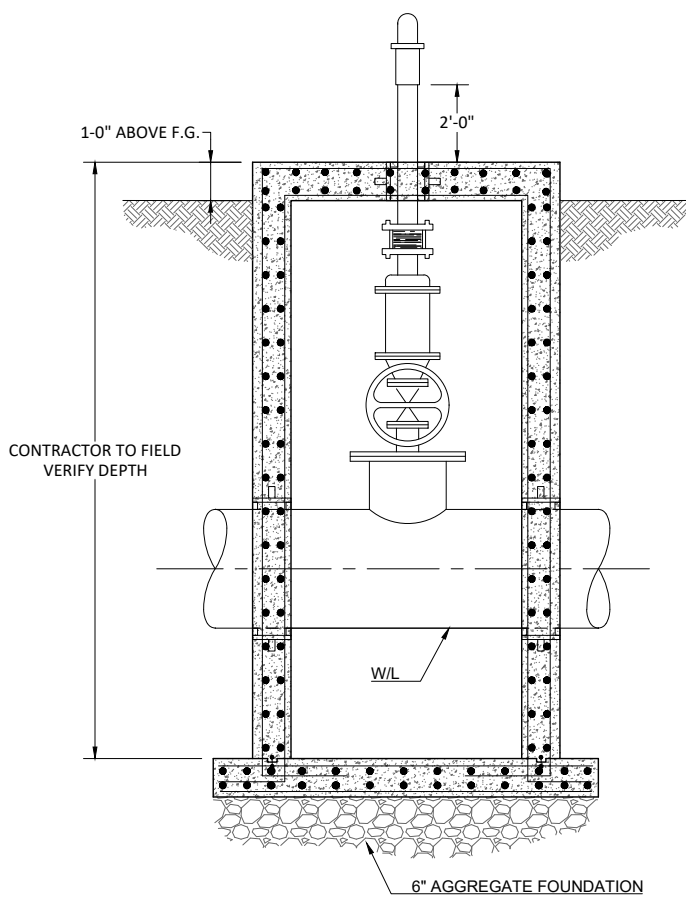

SECTION B-B

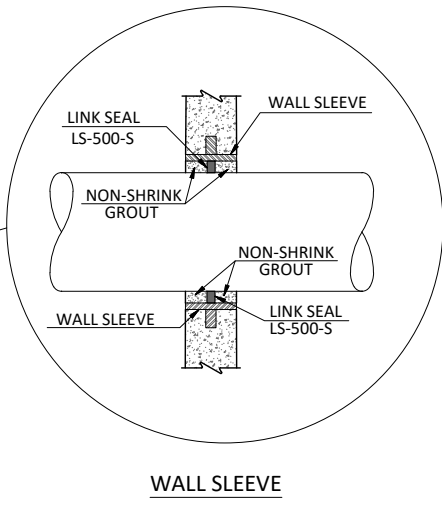
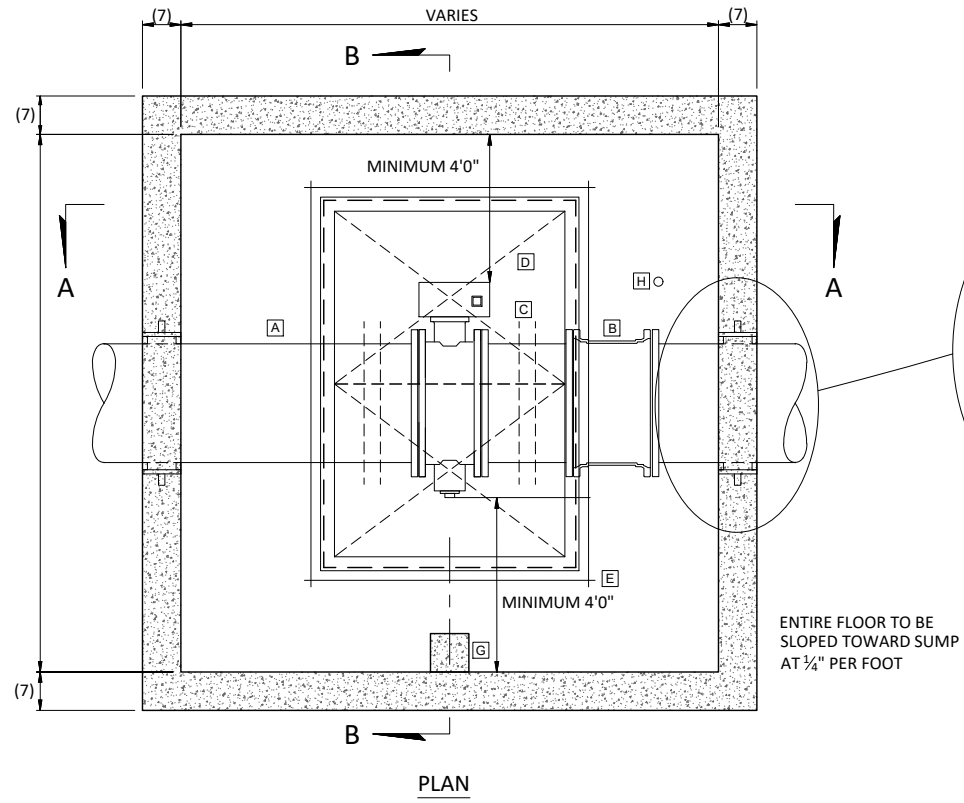

- NOTES:
1. VAULT TO BE STRUCTURALLY DESIGNED BY ENGINEER.
 2. ALL DUCTILE IRON JOINTS INSIDE THE VAULT MUST BE FLANGED.
 3. VAULT ACCESS DOORS MUST BE ALUMINUM, RATED FOR 300 POUNDS PER SQUARE FOOT. ALL ATTACHING HARDWARE, AUTO LOCK, HINGES, SLAM LOCK WITH REMOVABLE KEY AND COMPRESSION SPRING ASSIST MUST BE 316 STAINLESS STEEL. DOORS MUST HAVE BUILT IN NEOPRENE CUSHION/GASKET, NON-OZONE DEPLETING BITUMINOUS COATING, DOUBLE LEAF CONSTRUCTION, EXTRUDED ALUMINUM CHANNEL FRAME AND RECESSED LIFTING HANDLE AND INSTALLED PER MANUFACTURER RECOMMENDATION. HATCH COVER MUST HAVE SAFETY FALL GRATING AND LADDER UP EXTENSION
 4. FOR VAULTS LOCATED WITHIN VEHICULAR TRAVELLED SURFACES, THE VAULT MUST BE DESIGNED FOR THE PROPER VEHICLE LOADING CONDITIONS. HATCH COVER MUST HAVE HEAVY DUTY FRAME WITH SAFETY FALL GRATING AND LADDER UP EXTENSION.
 5. PROVIDE STRAIGHT PIPE UPSTREAM AND DOWNSTREAM OF METER/STRAINER IN ACCORDANCE WITH MANUFACTURER'S REQUIREMENTS.
 6. WALL AND SLAB THICKNESS NOT DRAWN TO SCALE TO BE DETERMINED BY THE ENGINEER
 7. REINFORCING NOT DRAWN TO SCALE TO BE DETERMINED BY THE ENGINEER.
 8. GRAVEL SUMP PITS WILL NOT BE PERMITTED.

MATERIALS LEGEND		
ITEM	QTY	DESCRIPTION
A	1	D.I.P. FL-PE 20 FT. LONG
B	1	FLANGE COUPLING ADAPTER
C	1	D.I.P. FL-FL 3 FT. LONG
D	1	BUTTERFLY VALVE, FL
E	1	DOUBLE LEAF ALUMINUM DOOR W/ SAFETY FALL GRATING (NOTE2)
F	1	CONCRETE PIPE SUPPORT
G	1	12" X 12" CONCRETE SUMP PIT
H	1	SAFETY ANCHOR
I	1	2" TAP AND BALL VALVE

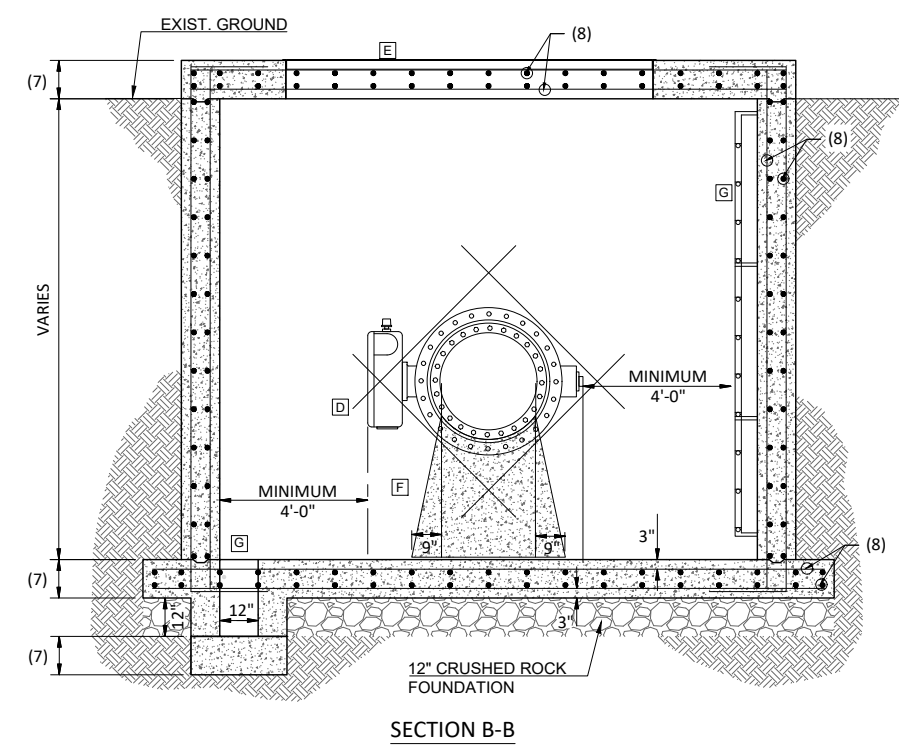
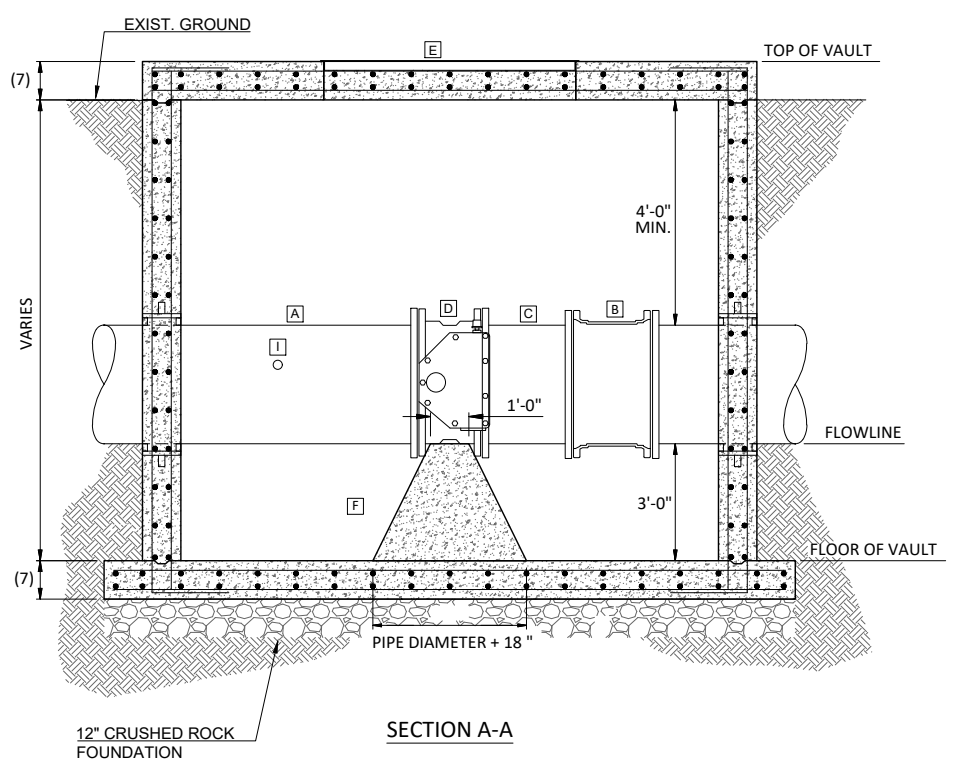

08 VALVE VAULT INSTALLATION
512 Scale: N.T.S.

APPROVED BY: *Deborah K. Miller* 10/16/2023 DATE: 10/16/2023
Chris Browning 10/10/2023 DATE: 10/10/2023
Will Huggins 10/10/2023 DATE: 10/10/2023
 DEBORAH K. MILLER, P.E., INTERIM CITY ENGINEER
 CHRIS BROWNING, GENERAL MANAGER
 WILL HUGGINS, P.E., DEPUTY DIRECTOR
 UTILITIES ENGINEERING

WATER STANDARD DETAILS
VALVE VAULT
DETAILS 512.08

512.C