

Case No: SPUD-1685

Applicant: Arturo De Lara Escalera

Existing Zoning: C-4 / AA / PUD-771

Location: 3104 NE 82nd St.

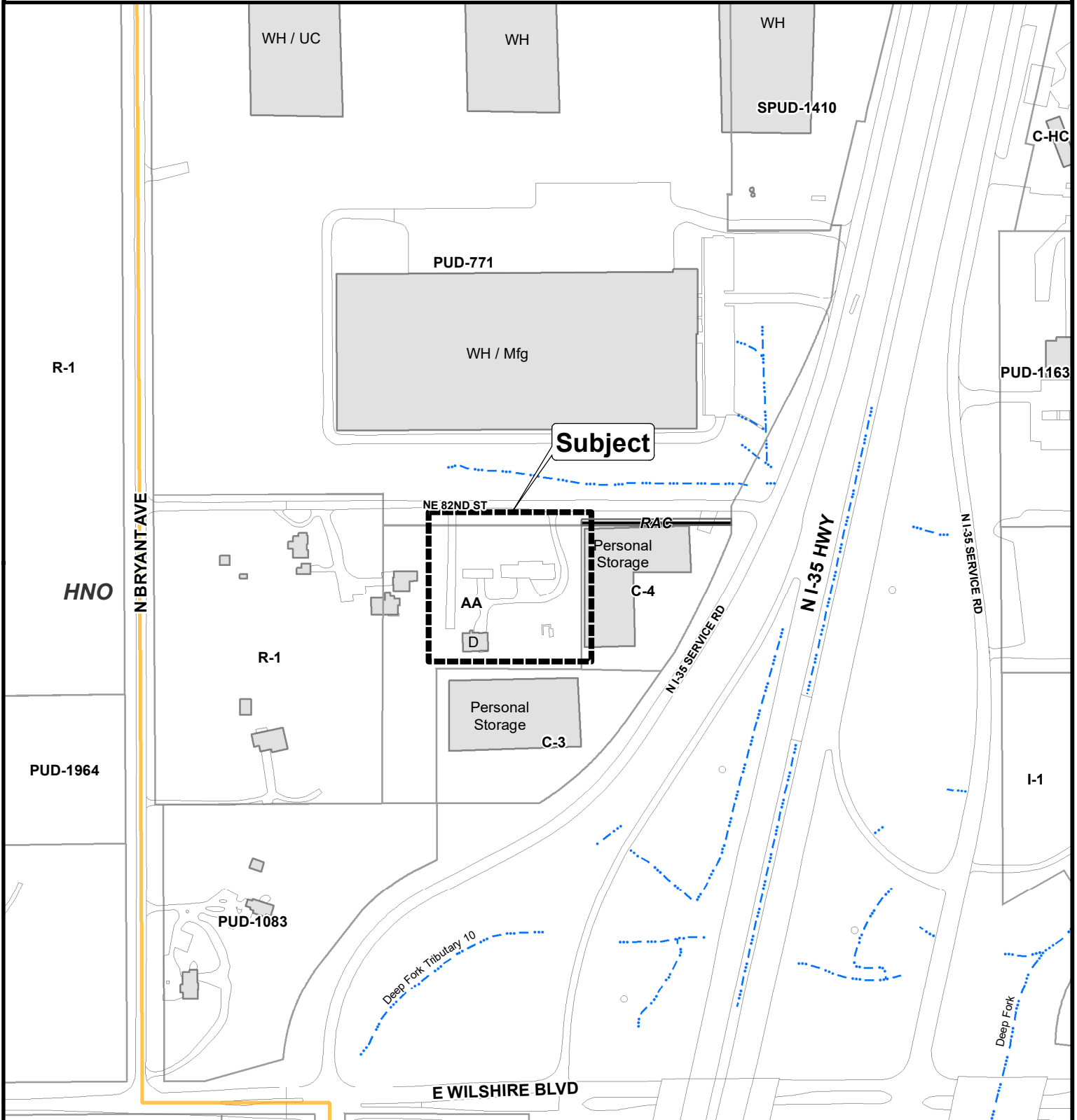

The City of OKLAHOMA CITY

# Simplified Planned Unit Development

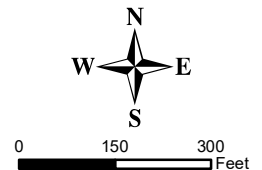

To maintain consistency, preserve readability, and minimize delays please maintain the formatting of this document to the maximum extent possible.

Sections may be added as necessary.

THE CITY OF OKLAHOMA CITY  
SIMPLIFIED PLANNED UNIT DEVELOPMENT

SPUD-(number)

MASTER DESIGN STATEMENT

(Revision Date)  
(Revision Date)

**PREPARED BY:**

Roca Engineering, Inc.  
3200 NW 38<sup>th</sup> Street  
Oklahoma City, Ok 73112  
(405-684-8920)  
(vpozadas@rocaengineering.com)

# **SPUD-(number) MASTER DESIGN STATEMENT**

This document serves as the Master Design Statement and fulfills the ordinance requirements for the Simplified Planned Unit Development (Chapter 59, Section 14150.B of the Oklahoma City Municipal Code, 2020, as amended).

## **I. Special Development Regulations:**

The following Special Development Regulations and/or limitations are placed upon the development of the Simplified Planned Unit Development. Planning and zoning regulations will be those that are in effect at the time of development of this Simplified Planned Unit Development; provided, however, that the density and or intensity of the SPUD shall not be increased. Development is when a permit is issued for any construction or addition to any structure on a development tract. Certain zoning districts are referred to as a part of the Special Development Regulations of this Simplified Planned Unit Development. For purposes of interpretation of these Special Development Regulations, the operative and controlling language and regulations of such zoning districts shall be the language and regulations applicable to the referenced zoning districts as contained in the City of Oklahoma City's Planning and Zoning Code as such exists at the time of development of this Simplified Planned Unit Development. In the event of conflict between provisions of this SPUD and any of the provisions of the Oklahoma City Municipal Code, as amended ("Code"), in effect at the time a permit is applied for with respect to any lot, block, tract and/or parcel of land subject to this SPUD, the provisions of the Code shall prevail and be controlling; provided however, that in the event of a conflict between the Special Use and Development Regulations specifically negotiated as a part of this SPUD and the provisions of the Code in effect at the time a permit is applied for with respect to any lot, block, tract and/or parcel of land subject to this SPUD, such Special Use and Development Regulations of this SPUD shall prevail and be controlling.

1. This site will be developed in accordance with the regulation of the I-2" zoning district (OKC Zoning Ordinance, 2020, as amended), except that the following restrictions will apply:

The following use(s) will be the only use(s) permitted on this site:

Storage and handling of construction materials, sand, gravel, Portland

- 1.1 Minimum Lot Size: 1.52 Acres**
- 1.2 Minimum Lot Width: Per the base zone.**
- 2. Maximum Building Height:**
- 3. Maximum Building Size:**
- 4. Maximum Number of Buildings:**

There shall be a maximum of 1 buildings for dwellings, excluding accessory structures, in this SPUD.

**5. Building Setback Lines**

Front Yard: 25 Feet

Rear Yard: 10 Feet

Side Yard: 5 feet

Corner Side Yard: 5 feet

**6. Sight-proof Screening:**

Sight proof screening shall be per the base zone.

**7. Landscaping:**

The subject parcel shall meet all requirements of the City of Oklahoma City's Landscaping ordinance in place at the time of development.

**8. Signs:**

**8.1 Free standing accessory signs**

No freestanding signs shall be permitted

**8.2 Attached signs**

Attached signs shall be per the base zone.

**8.3 Non-Accessory Signs**

Non-Accessory signs shall be prohibited.

**8.4 Electronic Message Display signs**

Electronic Message Display signs shall be prohibited.

**9. Access:**

One access from NE 82nd Street.

**10. Sidewalks**

None.

**II. Other Development Regulations:**

**1. Architecture:**

Exterior building wall finish on all structures shall consist of a minimum 70% brick veneer, masonry, rock, stone, stucco, or wood, or other similar type finish. A maximum of 30%

EIFS (Exterior Insulation Finish System) material shall be permitted. Exposed metal or exposed concrete block buildings shall not be permitted.

**2. Open Space:**

A minimum of 25% open space, defined as no buildings or paving, shall be provided.

**3. Street Improvements:**

Street improvements shall not be required.

**4. Site Lighting:**

The new structure and any modifications thereto shall conform to applicable regulations. In the event of a new structure, the site lighting in this SPUD shall be in accordance with Chapter 59, Article XII, Section 59-12350 of the Oklahoma City Municipal Code, 2020, as amended.

**5. Dumpsters:**

Not needed, but trash collection facilities in this SPUD shall be in accordance with Chapter 49 of the Oklahoma City Municipal Code, 2020.

**6. Parking:**

A minimum of one parking space per dwelling shall be provided.

**7. Maintenance:**

Maintenance of the common areas in the development shall be the responsibility of the property owner. and docks, shall be permitted if installed in a manner to meet the requirements specified above.

**8. Drainage:**

Development of this parcel will comply with Chapter 16 of the Oklahoma City Municipal Code, 2020, as amended.

**9. Other:**

N/A

**III. Supporting Documents**

Exhibit A: Legal Description

Exhibit B: Site Plan

# LEGAL DESCRIPTION

**3104 NE 82<sup>ND</sup>**

**OKLAHOMA CITY, OK 73131**

UNPLTD PT SEC 31 13N 2W 000 000 PT SW4 SEC 31 13N 2W BEG AT A POINT 25FT S & 462FT E OF NW/C SD GOVT LOT 4 TH E180.55FT S348.04FT W145.88FT TH NWLY TO A POINT 256.58FT S & 479FT E OF NW/C SD GOVT LOT 4 TH NWLY TO A POINT 141.08FT S & 469FT E OF SD NW/C TH NWLY TO A POINT 25FT S & 462FT E OF SD NW/C GOVT LOT 4 TO POINT OF BEG

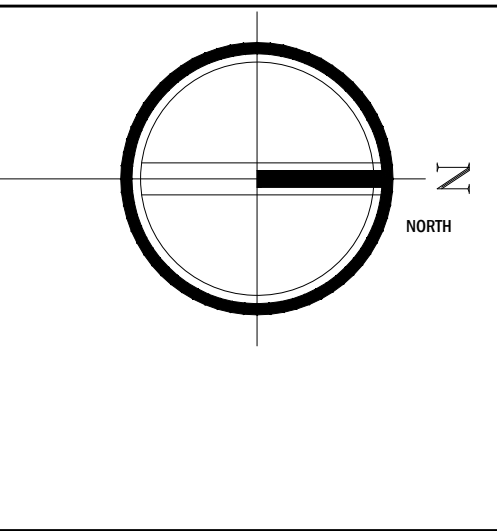
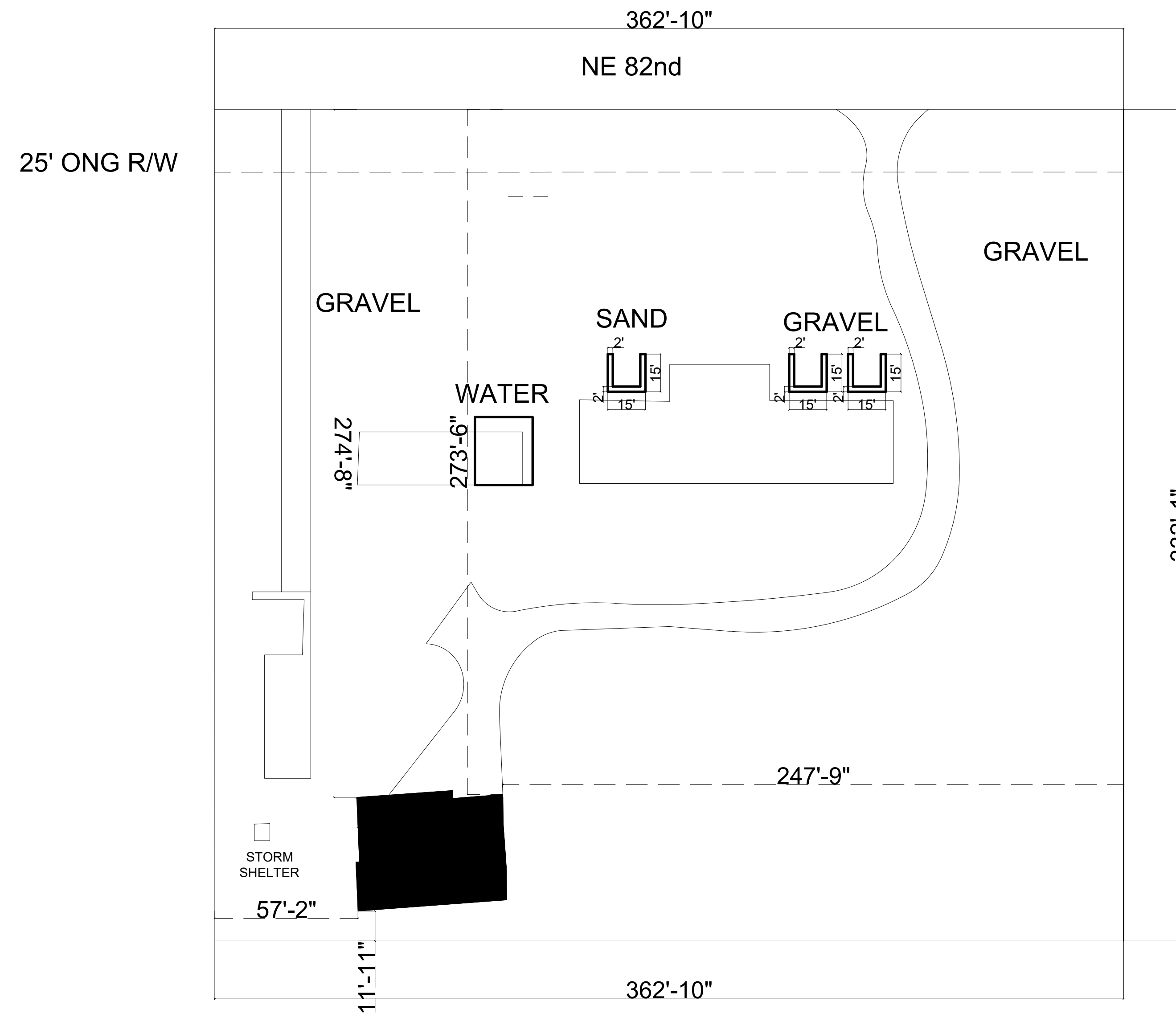

3104 NE 82nd St,  
 OKLAHOMA CITY

MARK	DATE	DESCRIPTION
REV A	4/3/19	FLOOR PLAN
REV B	4/16/19	WARE HOUSE PLANS

**DRAWING:**

**CARPORT**

PROJECT # CD14-19      Checked: VP      Drawn By: YL

SCALE:      DATE:

REVISION: