



# MEMORANDUM

## The City of OKLAHOMA CITY

**TO:** Frances Kersey, City Clerk  
Dennis Clowers, P.E., City Engineer

**FROM:** Marsha Slaughter  
Director of Utilities

**DATE:** May 29, 2007

**SUBJECT:** Revision #1 to "Specifications for Water Meters and Water Service Installations" dated August 1, 2006

As authorized in Section O, "Compliance with these Specifications", Item 5. of the subject specifications, the attached revision is to replace the 2006 version of the specifications and shall have the same authority as the original from this date forward.

A summary of the changes is as follows:

Section C, "Water System Taps", Subsection 1, "Tapping Procedures", c., "Water Service Line Dead Ends", Item (5) is revised to reflect current practice and eliminate confusion regarding a double configured dead end.

Section E, "Meters", Subsection 4, "Additional requirements for meters three inches (3") and larger ("large meters")", Item g. is revised to remove confusion and clearly state the requirement for all 3" and larger domestic meters to have a bypass meter installed to facilitate repair and maintenance by City crews with no service interruption to the customer.

Section I, "Water Service Lines", Subsection 1, "Generally", Items e. and h. are redundant. Delete item e. and re-letter remaining items in this subsection.

Section I, "Water Service Lines", Subsection 1, "Generally", add new item i. that specifically states that manifold set-ups for water meter installations are not allowed. This formalizes the consensus between the Director, Water Engineering and Utility Customer Service (as addressed in an e-mail dated 2/5/07).

Please release the existing 2006 version of the specifications with Revision (1).

**THE CITY OF OKLAHOMA CITY SPECIFICATIONS  
FOR WATER METERS AND WATER SERVICE INSTALLATIONS**

These specifications apply to the construction, installation, repair, and replacement of any water facilities on any public property which facilities are connected or to be connected, directly or indirectly, to the Oklahoma City water system. Any person constructing, installing, repairing, or replacing water facilities on public property must comply with these *The City of Oklahoma City Specifications for Water Meters and Water Service Installations* (“Specifications”). Any variation to or deviation from these Specifications must be approved by the Director of the Water and Wastewater Utilities Department (“Director”) or designee in writing prior to commencement of construction, installation, repair, or replacement.

A. General Requirements – Plumbers and Water Contractors

1. Every person constructing, installing, repairing, or replacing water facilities on public property must comply with these Specifications and must obtain, maintain, and provide to the Oklahoma City Water and Wastewater Utilities Department a current copy of the following before commencing any excavation, installation, construction, repair, or replacement:

a. License:

- (1) State of Oklahoma and/or Oklahoma City journeyman plumber/plumbing contractor’s license (hereinafter a person holding either current Plumbers license is referred to as “Plumber”); or
- (2) Current status as a prequalified Water Contractor granted by the Oklahoma City Prequalification Review Board and an Oklahoma City Water Contractor’s license (hereinafter a licensee holding a current Water Contractor’s license is referred to as “Water Contractor”);
- (3) Only persons qualified under Items A.1.a.(1) and A.1.a.(2) may construct, install, repair, or replace water service lines, water meters and water meter facilities.

- b. Certificate of Insurance: General Liability Coverage
  - (1) Naming The City of Oklahoma City and the Oklahoma City Water Utilities Trust as additional insureds;
  - (2) In the amount of \$1,000,000 (Aggregate Liability); and
  - (3) On an Oklahoma City approved form.
- c. Proof of financial viability:
  - (1) Right-of-Way Bond on an Oklahoma City form in principal amount of ten thousand (\$10,000) dollars; or
  - (2) Be a pre-qualified Water Contractor in good standing (most recent letter from the Public Works Department).
- d. Class “D” Water Operators License
  - (1) Issued by Oklahoma Department of Environmental Quality to the Plumber or Water Contractor or any employee of the Plumber or Water Contractor installing water meters in The City of Oklahoma City.
- e. Worker’s Compensation Insurance:
  - (1) Provide and maintain with the Oklahoma City Water and Wastewater Utilities Department a copy of a current certificate of worker’s compensation insurance throughout the period within which the Plumber or Water Contractor will install, construct, repair, or replace Public Water Facilities; or
  - (2) If the Plumber or Water Contractor does not have any employees other than himself or herself, then the Plumber or Water Contractor must provide and maintain with the Oklahoma City Water and Wastewater Utilities Department:
    - (a) A copy of a current worker’s compensation exemption card issued by the Oklahoma Department of Labor; and
    - (b) A statement that the Plumber or Water Contractor does not have any employees, which statement must be updated every time the Plumber or Water Contractor is re-issued a

worker's compensation exemption card by the Oklahoma Department of Labor.

2. All required licenses, insurance, and permits are to be available on the job site and immediately available upon request of any Oklahoma City employee.
3. Authorization for construction, installation, repair, or replacement of certain types of Public Water Facilities:
  - a. Plumbers may work on water mains and water service lines up to and including three (3") inches in diameter including associated water meters and water meter facilities providing domestic service to a residence, commercial, industrial, or governmental site. Plumbers may also work on private fire service lines and private sprinkler lines less than four (4") inches in diameter. Plumbers may not make street cuts, set fire hydrants, or extend water mains unless on the Public Works Prequalification list.
  - b. Water Contractors may work on any water main, , public fire lines up to and in excess of six (6") inches in diameter and private fire line in excess of four (4") inches in diameter and associated water facilities. Water Contractors with appropriate prequalification, license, and permits may make street cuts, set fire hydrants, and install, maintain, repair, or replace water mains.

**B. Warranty and Maintenance**

1. In exchange for permission to construct, install, repair, or replace any water service lines and water meters, the Plumber or Water Contractor warrants the water service lines and water meters free of all defects and in compliance with these Specifications until acceptance by The City of Oklahoma and for such maintenance period after acceptance as provided in these Specifications.
2. The water service lines and water meters and meter facilities will be deemed accepted by The City of Oklahoma City after completion of the installation of water service lines and water meters and passing final inspection (Initial inspection during construction, installation, repair or replacement will be sufficient to be deemed final inspection). Plumbers or Water Contractors will be notified monthly of warranty work required and will be given forty-five (45)

calendar days from the notification date to complete such warranty work. They are also responsible for notifying the designated administrator in the Water and Wastewater Utilities Department Utility Customer Service Division in a timely fashion when warranty or maintenance work is complete and ready for inspection.

4. The New Service Supervisor will notify Plumbers or Water Contractors if submitted warranty work requires further action to meet Specifications and may authorize additional calendar days to resubmit such warranty work.
5. Warranty work not completed within forty-five (45) calendar days will result in the Plumber or Water Contractor being unable to schedule or perform any further or additional installations of water service lines, water meters, or meter facilities until past due warranty work is satisfactorily completed and inspected.
6. The Plumber or Water Contractor will perform any required warranty work and maintenance on any water service lines, water meters, and meter facilities they construct, install, repair, or replace to bring said water service lines, water meters, and meter facilities in compliance with these Specifications, regardless of cause, until the expiration of the maintenance period following acceptance by The City of Oklahoma City.
7. Should any water service line, water meter, or meter facility be or become in non-compliance with these Specifications after the expiration of the warranty and maintenance period due to the addition, installation, or alteration of the property or any structures or improvements thereon or due to any act or omission of the property owner or any agent of the property owner, then the water facilities must be repaired, replaced, relocated and/or re-installed by the property owner or the water service customer.
8. The Utility Customer Service Division shall provide notice of non-compliance and a demand for compliance to the party responsible party. Notices to Plumbers or Water Contractors shall be to their last known address. Notices to the property owner shall be to the address listed in the County Assessor's Office. Notice to the water service customer shall be to the billing address.
9. Should the Plumber or Water Contractor fail to comply within forty-five (45) calendar days, the Utility Customer Service Division may perform the necessary

repair, replacement, relocation or reinstallation at the Plumber or Water Contractor's expense. Failure to comply may preclude the Plumber or Water Contractor from performing any further work under these Specifications, and may seek recovery of all costs and expenses through any remedy available to it.

10. Compliance with these Specifications is a condition of receiving and continuing to receive water services and a specific condition of the water service contract. Should the said property owner and water customer fail to comply within forty-five (45) calendar days, the Utility Customer Service Division may terminate water service and/or may repair, replace, relocate and re-install the water facilities and charge all necessary costs and expenses to the water service customer on their water service account.
11. During the warranty and maintenance period, the Plumber or Water Contractor is responsible for the repair, replace, relocate and/or re-install of any non-compliant water facilities to meet the requirements of these Specifications at the Plumber or Water Contractor's expense.
12. Neither The City of Oklahoma City nor the Oklahoma City Water Utilities Trust shall be responsible for any damage, loss, or expense related to the failure of any party to comply with these Specifications.
13. Warranty and maintenance work includes, but is not limited to, the following:
  - a. Repair, replace, raise, lower, level, relocate or re-install any broken, missing, or improperly located water service line, water meter or meter facility regardless of cause;
  - b. Repair or replace any other construction, installation, labor, workmanship, or material defects to any water service line, water meter, or meter facility regardless of cause; and
  - c. Any other repair, replacement, re-installation, or relocation necessary for water service line, water meter, and meter facilities to comply with these Specifications, the Oklahoma City Municipal Code, or standard specifications adopted by The City of Oklahoma City, regardless of cause.
14. The maintenance period for repair, replacement, raising, lowering, leveling, relocating, or re-installing water service lines, water meters, and meter facilities

shall be for a period of two (2) years from the date of acceptance of such completed water service line, water meter, or meter facility; provided, however, the maintenance period shall extend beyond two (2) year period for any incomplete or unsatisfactory warranty or maintenance work for which the Plumber or Water Contractor was notified before the expiration of the two (2) year maintenance period. The maintenance period for broken water meter tiles, pits and vaults is from the date of installation up to and including six (6) months from the date the premise is changed into the name of the first customer other than the developer/builder.

15. The maintenance period shall extend until the completion in accordance with these Specifications and acceptance of all warranty work of which the Plumber or Water Contractor was notified before the expiration of the two (2) years maintenance period.
16. All warranty work will be performed at no cost to The City of Oklahoma City or the Oklahoma City Water Utilities Trust.
17. The Water Contractor or Plumber shall be responsible for contacting Okie Locate and obtaining utility information prior to boring, excavating, trenching, or cutting paving.

C. Water System Taps

This section addresses all taps, directly or indirectly, connecting to the Oklahoma City water system unless otherwise specifically stated. All taps must be performed in the presence of the Distribution System Inspector.

1. Tapping Procedures

a. Generally

- (1) All water service line and meter facility installations must be inspected and approved before being covered and before water service may be commenced through such water meter or water service line. All water meter installations must be inspected and approved before water service may be commenced through such water meter or water service line.

- (2) The Plumber or Water Contractor must schedule an inspection of all water service line, water meter, and meter facility installations to include taps and dead ends by calling the Distribution System Inspection Desk for the Utility Customer Service Division (“Distribution System Inspector”) during regular Oklahoma City business hours on a regular City work day in accordance with established procedures and these Specifications.
- (3) The Plumber or Water Contractor must present all construction, installation, repair, or replacement work, whether original work, warranty, or maintenance work, for inspection in an open trench so that the Distribution System Inspector will have an unobstructed view of and access to all work. If any work presented for inspection is not exposed and available for inspection at the time of the scheduled inspection, the Distribution System Inspector will not inspect such work and the Plumber or Water Contractor will be required to schedule a new inspection appointment when the trench is subsequently opened or re-opened.
- (4) Should the Distribution System Inspector determine it necessary to enter the trench, the Plumber or Water Contractor must make the trench safe and reasonably accessible to the Distribution System Inspector.
- (5) All trenches and excavations must meet applicable federal (including but not limited to OSHA), State of Oklahoma, and Oklahoma City standards and specifications.
- (6) The Plumber or Water Contractor may only tap the Oklahoma City water system in the presence of a Distribution System Inspector. No water service shall be provided prior to approval of the tap by the Distribution System Inspector. Taps made without the Distribution System Inspector present is a violation of the Oklahoma City Municipal Code Chapter 55, Section 55-46 and will result in the Plumber or Water Contractor being cited.



- (7) The Plumber or Water Contractor may not crimp or permit a crimp in the public water service line to occur. The Plumber or Water Contractor must compact the soil in and around the trench, either by hand tool or machine, in a manner that will avoid crimping the public water service line when backfilled. The Plumber or Water Contractor must replace any portion public water service line that is or becomes crimped during the warranty or maintenance period.
- (8) Prior to tapping the public water main or commencement of the construction, installation, repair, or replacement of any Public Water Facilities across any property owned by another party, the Plumber or Water Contractor must obtain and provide to the Water and Wastewater Utilities Department a properly executed easement on a form approved by Oklahoma City.
- (9) Prior to tapping the public water main or commencement of the construction, installation, repair or replacement of any private water service line installed across Oklahoma City property or easement or Oklahoma City or public right-of-way to which the service address owner is not the fee property owner, the Plumber or Water Contractor must obtain a revocable permit from The City of Oklahoma City.
- (10) All water mains, fire hydrant leads and fire lines on the inlet (supply) side of the meter tailpiece must be dedicated and accepted by The City of Oklahoma City prior to initiation of water service. All water facilities on the outlet (customer) side of the meter tailpiece shall be part of the private water system and owned and maintained by the property owner.
- (11) All necessary easements must be dedicated and accepted prior to commencement of any public water main tap or the construction, installation, repair, or replacement of any public water service line.
- (12) All water mains, fire hydrant leads and fire lines must be inspected and approved, all permits must have been obtained, and all

applicable fees must have been paid, prior to the release and installation of a water meter or commencement of water service.

b. Back taps and reverse taps

- (1) Back taps and reverse taps will not be allowed except as approved in writing in advance of installation by the New Service Supervisor.
- (2) The New Service Supervisor may only approve reverse or back taps when, in his or her sole discretion, warranted by adverse conditions not caused or reasonably avoidable by the Plumber or Water Contractor.
- (3) Neither financial economy nor additional expense shall be considered a basis for approval of a reverse or back tap.

c. Water Service Line Dead Ends

- (1) The dead end of a water service line must be within four feet (4') of the property line that is perpendicular to the Oklahoma City utility easement or the public right-of-way and must be on the property being served or to be served. Whenever the assigned water service line dead end is not within four feet (4') of the property line to be served, the water service line must be relocated or replaced, including if necessary re-tapping the public water main. The relocated or replaced water service line must be re-inspected at the expense of the Plumber or Water Contractor and at no cost or expense to The City of Oklahoma City or the Oklahoma City Water Utilities Trust.
- (2) The improperly installed water service line must be removed all the way to the public water main and the tap properly plugged in accordance with these Specifications. No water meter may be installed or water service commenced through a water service line that does not meet these Specifications.
- (3) Should property lines be altered after installation of a water service line for whatever reason then it shall be the responsibility

of the developer or builder to provide new or revised plat or property description and to relocate or replace the subsequently non-conforming water service line at their expense and at no cost or expense to The City of Oklahoma City or the Oklahoma City Water Utilities Trust.

- (4) Upon written request of the Plumber or Water Contractor, the New Service Supervisor may, in his or her sole discretion, permit a long public water service line to be dead ended more than four (4') feet but not more than six (6') feet from the property line that is perpendicular to the Oklahoma City utility easement or the public right-of-way. If such water service line crosses another parcel of property or if installation necessitates private water service lines being located within public right-of-way or City utility easement, the Plumber or Water Contractor is required, among other things, to obtain a revocable permit from Oklahoma City prior to excavation, trenching, boring, or tapping for a water service line.
- (5) If the dead end of a water service line cannot be located at the time of water meter installation, then the property owner must either promptly locate the dead end or re-tap the water main and re-install a water service line at the property owner's expense and at no cost to The City of Oklahoma City or the Oklahoma City Water Utilities Trust.
- (6) Water service lines may not be dead ended under structures, driveways, roads, sidewalks, parking areas, or any area used or to be used for vehicular or pedestrian traffic. Water service lines may not be dead ended within five (5') feet of structures, driveways, roads, sidewalks, parking areas, or any area used or to be used for structures or vehicular or pedestrian traffic. Dead ends may be moved a maximum of six (6") inches to meet these requirements.
- (7) Dead ends and water services lines which violate any portion of this section must be re-tapped and the water service line reinstalled

at no cost to The City of Oklahoma City or the Oklahoma City Water Utilities Trust.

- (8) No water mains may be tapped and no water meter may be installed within the medians between the driveways or parking areas. Dead ends that are laid between the driveways or parking areas must be re-tapped and moved to within four (4') feet of the opposite property line perpendicular to the right-of-way so that the dead ends and water meter tiles are in an unpaved area at least five (5') feet from any driveway or parking area.

d. Water Meters

- (1) Water meters, water meter pits/vaults, and water meter tiles must be located in unpaved areas upon the property being served within public right-of-way or Oklahoma City utility easement.
- (2) Water meters, water meter pits/vaults and water meter tiles may not be buried or located within five (5') feet of or in or under structures, improvements, driveways, roads, sidewalks, parking areas or any area used or to be used for vehicular or pedestrian traffic.
- (3) Upon written request, the New Service Supervisor, may grant an exception and permit a water service line dead end or a water meter, water meter pits/vaults, or water meter tile to be closer than five (5) feet from any structure or improvement; provided, however, such authorization may only be granted and must be obtained in writing in advance of installation of such water service line dead end or a water meter, water meter pits/vaults, or water meter tile.
- (4) Water meters, water meter pits/vaults, and water meter tiles in violation of these Specifications must be removed or relocated to comply with these Specifications at no cost to The City of Oklahoma City or the Oklahoma City Water Utilities Trust.

- (5) Water service lines which connect to water meters, or pass through water meter pits/vaults, or under water meter tiles which are installed at locations prohibited by or in non-conformance of these Specifications must be re-tapped and relocated and the non-conforming water service line removed, turned off, and plugged at the water main.

e. Tapping Fire Hydrant Leads or Fire lines

- (1) Only dedicated public fire hydrant leads and fire lines in Oklahoma City easements or the public right-of-way can be tapped. The tap must be on the main side of the pit and a gate valve must be installed between the double check valve assembly and the tap. The public fire line, gate valve, isolation valve, and cut off valve must be dedicated to and accepted by the City prior to initiation of water service through these facilities. Fire line installations and water pit construction must be inspected concurrently by the Public Works Department and the Distribution System Inspector.
- (2) A private fire hydrant lead or private fire line may never be tapped for a public water service line. Taps on fire hydrant leads or fire lines will not be allowed except as approved by the New Service Supervisor in writing in advance of the tap.
- (3) The New Service Supervisor may only approve fire hydrant lead or fire line taps when, in his or her sole discretion, the tap is warranted by adverse conditions not caused or reasonably avoidable by the Plumber or Water Contractor. Neither financial economy nor additional expense shall not be considered a basis for approval of a fire hydrant lead or fire line tap.
- (4) Taps on fire hydrant leads or fire lines will not be approved to eliminate boring the street.
- (5) A fire hydrant lead or fire line must be at least six (6") inches in diameter and in the case of the fire hydrant lead the tap must be

made between the tapping valve/gate valve and the watch gate valve.

- (6) Whenever a water service line is connected to a fire line or fire hydrant lead, the Distribution System Inspector must inspect and approve the water service line from the connection on the fire line or fire hydrant lead to the private water service line connection, including but not limited to the water meter and meter facilities.
- (7) An isolation valve shall be installed between the private fire line and the water service line. An isolation valve must be installed between backflow prevention device and water service line tap.
- (8) No single water service line shall be permitted for fire line and water service line without an approved split, separate water meter, backflow prevention device, and isolation valve. No service less than one and a half (1 ½”) inches in diameter may be split.
- (9) Private fire lines and private fire hydrant leads must have a double check valve assembly on the outlet (customer) side of the fire line connection to the public water service line.
- (10) The following procedures shall be followed when tapping a fire hydrant lead:
  - (a) To relocate a fire hydrant for domestic service installation you must be a Pre-Qualified Licensed Water Contractor.
  - (b) The following must be submitted to Water Engineering prior to the hydrant relocation:
    1. A letter stating relocation of fire hydrant for service installation and stating this will be at no cost to the City, a map showing fire hydrant relocation and service taps, and an insurance certificate with notary statement.
    2. The letter will be sent to the Chief Inspector – Water Line Inspection, Public Work Field Services, to inspect the relocation.

3. The line must be tested and disinfected and the service taps will be inspected by Public Works. Taps must be thirty-six (36) inches apart, made at a point within forty-five (45) degrees of the crown of the pipe and staggered at least fifteen (15) degree angles either way of each other.

4. Chief Inspector – Water Line Inspection, Public Work Field Services will notify Water Engineering when the relocation and testing is complete.

5. The water meter card will be released to Utility Customer Service Field Operations for the Pre-Qualified Licensed Water Contractor on the approved plumbers list or approved plumber to schedule the water meter installation.

(c) Plumbers and Water Contractors must provide the New Service Supervisor with a set of plans pre-approved by the Engineering Division of the Water and Wastewater Utilities Department prior to tapping a public fire line.

(11) Any tap of a public fire line must be on the public water main side of the pit and must have a gate valve in front of the detector check/double check valve assembly.

## 2. Technical Work Requirements

a. Direct water service line taps may only be allowed on water distribution mains.

b. Except as specifically approved in writing in advance as provided in these Specifications, all water service line taps must be made on water distribution mains. A water transmission main may not be tapped. To obtain water from a water transmission main, the Water Contractor must install a public water main of a size not less than six inches (6”) in diameter.

c. Taps for water service lines will be allowed on water distribution mains up to twenty (20) inches in diameter. Taps for water service lines on

water transmission mains larger than twenty (20) inches will require the installation of a water distribution main not less than six (6) inches in diameter.

- d. All water service line taps of water distribution mains or fire hydrant leads or fire lines (if permitted) must be made at a point within forty-five (45) degrees of the crown of the water distribution main
- e. Any Plumber or Water Contractor making water service line taps on a water distribution main, fire hydrant lead or fire line (if permitted), must maintain at least three (3') feet between each tap and must stagger the point of the tap at least fifteen (15) degree angles either way of each other.
- f. Water service lines must be free from crimps and must include a ball valve between the corporation and the meter setter.
- g. Water distribution mains, fire lines and fire hydrant leads may not be directly tapped for private water systems. Private water systems may only be connected to the Oklahoma City water system by a public water service line.
- h. A minimum of one-inch (1") water tap and one-inch (1") water service line is required whenever a new tap is made for water service; however, existing water service lines may be replaced with the original size water service line if no new water tap is required or made.

D. Tapping Saddles

1. Tapping saddles: One inch (1") public water service lines.

- a. A brass or cast iron tapping saddle is required whenever tapping a water distribution main, fire hydrant lead, or fire line for a one inch (1") water service line.
- b. Either a brass tapping saddle with stainless steel straps and bolts or a brass tapping saddle with brass straps is required whenever tapping a PVC main or an existing cast-iron or ductile-iron pipe; provided the Distribution System Inspector may, at his or her discretion, permit a direct tap into a new or existing cast-iron and ductile-iron mains without a tapping saddle.
- c. The tapping saddle must be the same size as the water service line.



- d. The tapping saddle may not be reduced to the size of the water service line.
2. Tapping saddles: One and one-half inch (1-1/2") and larger water service lines.
- a. Ductile iron tapping saddles are required whenever tapping a water distribution main, fire hydrant lead, or fire line for a one and one-half inch (1-1/2") and larger water service line; provided the Director, in his or her discretion, may amend these Specifications to permit other proven reliable types of taps.
  - b. Solid back tapping saddles are required whenever tapping a water distribution main which is four-inch (4") or smaller in diameter for a water service line. Tapping of a four (4") inch or smaller water distribution main is discouraged.
  - c. Solid back tapping saddles with four-bolt epoxy-coated alloy bolts are required for water service line taps three-inch (3") in diameter and larger. Neither shop-coat bolts nor strap style tapping saddles will be allowed for water service line taps three-inch (3") in diameter and larger.
  - d. After the tapping saddle is installed on a water distribution main and the tap has been made, the Plumber or Water Contractor, at its own expense and in the presence of the Distribution System Inspector, must perform and pass an air test. The Director will designate the acceptable standards and methods for performing the air test on all services three (3") inches in diameter and larger. Tapping saddles must hold eighty (80) to ninety (90) pounds of pressure for thirty (30) minutes without leaking or causing damage to the water distribution main (or where applicable, fire hydrant lead or fire line), tapping saddle, or water service line.
  - e. No reduction from tapping saddles to water service lines will be permitted, except that a four inch (4") tapping saddle may be reduced for a three inch (3") water service line.
  - f. A four inch (4") diameter water distribution main may not serve more than six (6) one-inch diameter water service lines or the equivalent thereof.

- g. A four inch (4”) diameter water distribution main that dead ends must have a blow off at its dead end.

E. Meters (This section addresses all meters including water meters, sprinkler meters, and irrigation meters, unless otherwise specifically stated.)

1. Generally

- a. No meter may be installed for the purpose of selling or re-selling Oklahoma City water within the City of Oklahoma City or the Oklahoma City water service area without the prior written permission of the Director.
- b. No water meter may be installed unless the property to be served has been assigned a permanent address, street signs and house numbers have been established, and the permanent address including street name and house number are visible on job site.
- c. Water meters may not be installed unless the foundation of the structure is present; less and except private irrigation or sprinkler meters may be installed after the satisfactory completion and inspection of the private irrigation system.
- d. Meters may not be installed unless a completed and inspected private water service line meeting the most recent plumbing code adopted by Oklahoma City is in place.
- e. Meters may not be installed unless a satisfactorily completed and inspected water service line meeting these Specifications is in place.
- f. The Distribution System Inspector must be present when the Plumber or Water Contractor sets the meter. The arrow on meter must point to outlet (customer) side of the meter and the private water service line.
- g. All meters and meter facilities must be installed on City property, City easement or public right-of-way except where pre-approved by the Director.
- h. After the water service line and the private water service line are installed and meter is set, and before service is backfilled, the water must be turned on at the corporation in the presence of the Distribution System Inspector

to check for leaks. Should there be a leak, the water will be turned off and the Plumber or Water Contractor must repair the leak(s) at his/her own expense. The water must again be turned on at the corporation in the presence of the Distribution System Inspector and the Water Facilities must again be checked for leaks.

- i. All meters three inches (3”) in diameter and larger must be compound meters.
- j. Turbine meters may be permitted if approved by the Distribution System Inspector prior to installation.
- k. Meter tailpieces shall be “Type K” copper in composition and eighteen (18”) to twenty-four inches (24”) in length.
- l. Meters installed in the City easement or right-of-way are owned by Oklahoma City unless specifically designated otherwise by the Director on the approved plans.

2. Sprinkler meters

- a. Any meter that is used for non-domestic services is considered a non-domestic service meter.
- b. A non-domestic service meter requires the same installation procedures as a domestic meter with the exception an approved backflow prevention device must be installed and inspected on a non-domestic service line in accordance with these Specifications before a non-domestic service meter may be set.
- c. Non-domestic service meters are different and distinct from deduct meters.
- d. Non-domestic service meters must have a separate meter box.
- e. Water service lines connected to non-domestic service meters must either have:
  - (1) a separate water main tap from the water service line servicing the private water service line for domestic services; or
  - (2) an acceptable backflow prevention device in accordance with the current International Plumbing Code.

3. Miscellaneous connections and valves

- a. A “T” connection may not be used to connect a private water service line to a public water service line two (2”) inches in diameter or less except upon prior approval from the Distribution System Inspector on a water service line. Approval and the permit must both be obtained prior to scheduling an inspection of the connection and must be noted by the Distribution System Inspector on the permit. It shall be the responsibility of the property owner to maintain a record of approval of a “T” connection.
- b. “T” connection may be used to connect a lawn sprinkler system to a private water service line. Approval and the permit must both be obtained prior to scheduling an inspection of the connection and must be noted by the Distribution System Inspector on the permit. It shall be the responsibility of the property owner to maintain a record of approval of a “T” connection.
- c. “Y” connections and “T” connections may only be installed for splits of one and one-half (1-½”) inches or (2”) two-inch water service lines. Splits must be approved and noted on the permit by the Distribution System Inspector prior to installation. It shall be the responsibility of the property owner to maintain a record of approval of a “T” or “Y” connection.
- d. Elbows, “T” connections, and “Y” connections may never be used or installed on water service lines larger than two (2”) inches or water service lines connecting to water meters larger than two (2”) inches.
- e. Throttling valves, check valves, backflow prevention devices, and pressure regulating devices shall not be closer than twenty (20) times pipe diameter outside of the meter box on the outlet (customer) side. Under no circumstance may throttling valves, check valves or backflow prevention devices be permitted in the same meter box with the water meter. Throttling valves, check valves or backflow prevention devices must be installed in their own meter pits/vaults.

- f. All water service lines two (2") inches in diameter or less must have a curb stop installed inside the meter box prior to installation of the water meter. The top of curb stop must be on the inlet (supply) side of the water meter and at least eighteen (18") to twenty-four (24") inches below the inside top of meter box.
4. Additional requirements for meters three inches (3") and larger ("large meters").
- a. Large meters must be installed in meter pits/vaults and set on blocks a minimum of twelve inches (12") above the floor of the meter box.
  - b. Meter pits/vaults for large meters must be constructed in accordance with these Specifications prior to installation of the meter.
  - c. Large meter pits/vaults must have permanent walls in place.
  - d. Large meters must be centered in their meter pits/vaults shall have a minimum of eighteen-inch (18") clearance between the outside of the meter and the inside of each wall of the meter box. Any variations must be approved by the Distribution System Inspector prior to installation and noted by the Inspector on the permit. It shall be the responsibility of the property owner to maintain a record of approval of any approved variation.
  - e. All large meters require clear unobstructed pipe of a length at least five (5) times the pipe diameter on the inlet side (supply side) of the large meter between the meter and the isolation valve.
  - f. All large meters require clear unobstructed pipe of a length at least two (2) times the pipe diameter on the outlet side (customer side) of the large meter between the meter and the isolation valve.
  - g. To allow for meter repair and maintenance, large meters that require uninterrupted service must be installed with a bypass meter or a manifold system in accordance with these Specifications. All bypasses and manifolds systems must be separately metered.

F. Strainers

- 1. All turbine meters must have either an internal or external strainer.
- 2. Compound meters that are two (2") inches or larger must have strainers.

3. Strainers on all meters from two (2") inches to six (6") inches must be bronze.
4. Strainers on all meter eight (8") inches or larger must be cast iron.

G. Backflow Prevention devices

1. Backflow prevention devices are required for any water service line used as or in conjunction with non-domestic services.
2. Backflow prevention devices are required on any non-domestic service line and on private water service lines with periodic usage, such as frost free spigots.
3. Backflow prevention devices are required on private water service lines whenever a property is supplied with water from two (2) or more connecting water service connections. A backflow prevention device must be installed on the outlet (customer) side of each water meter on each private water service line.
4. Whenever backflow prevention devices are required, no meter will be installed or set before the backflow prevention device has been installed, inspected and approved by Public Works Plumbing Inspectors.
5. Backflow prevention devices shall be installed on the outlet (customer) side of the meter.
6. Backflow prevention devices must meet the standards set forth in the latest addition of the International Plumbing Code unless a different standard is adopted by the Director and added to these Specifications.
7. Backflow prevention devices should be installed not less than twenty-four (24") inches nor more than forty-eight (48") inches behind the meter box.

H. Meter Tiles, Pits, Vaults

1. Every meter must be housed in a meter tile, pit or vault approved by the Director.
2. Meter tiles, pit or vault must be set on firm unpaved surfaces and out of the line of sidewalks and drives.
3. Meter tiles, pits and vaults must be designed, constructed, installed, and located so as to allow free, safe, and easy access for reading, removal, inspection, replacement and repair of the meter and appurtenances.
4. Meter tiles, pits and vaults must be in the City right-of-way or City easement.
5. The top of the meter tile, pit or vault must be set at grade level. If the ground is not to final grade at the time of the installation of the meter box, then the

installing Plumber or Water Contractor must raise or lower the meter tile, pit or vault when the final grade is established.

6. Under no circumstances will corrugated steel meter pits/vaults or brick meter pits/vaults be permitted.
7. A “W” must be chiseled/cut in the curb in front of the meter box location.
8. The MSBCF-XL series meter box or other meter box and cover pre-approved by the Director are the only options for 5/8” to 2” meters that are installed in paved areas or traffic areas as specifically authorized by the Specifications.
9. Meter pits/vaults for meters of three inches (3”) and larger must comply with the latest standards established by the Director and be poured in place.
10. The meter pit or vault must be constructed and installed by the Plumber or Water Contractor or authorized subcontractor as a part of the service order.
11. The structural steel must be inspected and approved by the Distribution System Inspector or the Public Works Inspector (if Public Works is responsible for inspection of the project) before concrete is poured.
12. The meter pit/vault walls through which the inlet and outlet pipe passes must be properly sealed with bituminous material.
13. Upon completion in accordance with these Specifications, the meter pit/vault must be inspected and approved by the Distribution System Inspector before the meter can be set.
14. Pre-cast vaults are not authorized. All vaults must be poured in place.

I. Water Service Lines:

1. Generally
  - a. Water service lines shall not be installed in the same easements as sanitary sewer or storm drainage lines without prior approval of the Director.
  - b. A short water service line may not be longer than ten (10’) linear feet from the water distribution main. Any variation from the linear requirement must be approved by the Distribution System Inspector, and noted on the permit, prior to tapping the water distribution main.
  - c. All water service lines which pass under a road or are in excess of ten (10’) linear feet shall be considered long water service lines.

- d. Water service lines two (2") inches or less in diameter must be constructed from seamless copper tubing of the type designated "Type K" and all fittings must be brass. Substitutions such as "Type L" copper, plastic, or PVC pipe will not be accepted.
- e. Dead-end water service lines, less than one and one-half (1 ½") inches in diameter may not be split.
- f. A water service line may only have such unions as determined necessary by the Distribution System Inspector and shall be noted on the permit.
- g. The last fitting on the City side of the water service line must be a brass male or female union.
- h. Water service lines less than one and one-half inches (1 ½") in diameter may not be split.
- i. No water service will be provided through a water service line that does not comply with these Specifications.

J. Water Service Lines: Three-quarter (¾") inches to one inch (1")

- 1. Joints on water service lines less than one and one-half (1 ½") inches in diameter may not be sweated.
- 2. Three-quarters (¾") inch and one (1") inch in diameter water service lines may not be split.

K. Water Service Lines: One and one-half inches (1 ½") and larger

- 1. Water service lines of one and one-half (1-½") inches and two (2") inches in diameter must be type "K" copper and all fittings must be brass or copper.
- 2. Water service lines three (3") inches and larger in diameter must be ductile pipe or AWWA C-900, Pressure Class 200 Polyvinyl Chloride (PVC) pipe with a minimum Dimension Ratio of fourteen (DR-14) and must meet these Specifications and existing Oklahoma City standards and codes. If PVC pipe is to be used it must also meet the following additional standards:
  - a. All fittings shall be mechanical joint type as specified under ductile iron fittings and have polyethylene encasement tubing with a thickness of 8 Mil.



- b. One strand of number twelve (12) gauge copper tracer wire shall be installed along the top of the PVC pipe. Bring to top of ground and anchor all valves, fire hydrants and other appurtenances.
  - c. All joints shall be restrained using concrete thrust block or mechanical joint restraint for AWWA C-900. Joint restraints shall be manufactured by Ebba Iron Sales, Inc., or Uni-Flange by The Ford Meter Box Company, or approved equivalent.
  - d. Water service connections shall be with stainless steel tapping saddle and gasket.
  - e. If PVC pipe is used, the portion of pipe within the meter pit/vault shall be ductile iron to allow maintenance crews to weld without damaging the PVC pipe.
- 3. A water service line three (3") inches or smaller in diameter may not be connected by use of a "T" connection to a water meter of the same size as the water service line.
- 4. Sweating of joints is allowed for one and one-half (1-1/2") inch and (2") inch diameter water service lines, provided said joints are silflossed.
- 5. Water service lines may only be split as follows:
  - a. One and one-half (1-1/2") inch diameter water service lines may only be split as follows:
    - (1) Each one and one half (1-1/2") inch diameter water service line may be split to serve two (2) five-eighths (5/8") inch water meters.
    - (2) Each one and one half (1-1/2") inch diameter water service line may be split to serve two (2) one (1") inch water meters.
  - b. Two (2") inch diameter water service line may only be split as follows:
    - (1) Each two (2") inch diameter water service line may be split to serve up to four (4) five-eighths (5/8") inch water meters.
    - (2) Each two (2") inch diameter water service line may be split to serve up to three (3) one (1") inch water meters.
- 6. No other configuration for splitting of services will be permitted without approval by the New Service Supervisor.

M. Bores:

1. Generally:

- a. Copper lines utilized in bores under streets may not be spliced.
- b. Each bore of a street may only carry one water service line. Only one water service line per bore hole.
- c. Street bores must be a minimum of thirty (30") inches below the bottom of the paved surface.
- d. Bores for water service lines one (1") inch in diameter or smaller may not be larger than the size of water service line being installed plus a tolerance of no more than one (1") inch.
- e. Water Contractors and Plumbers must obtain all required boring and paving cut permits and have those permits on the job site and available for examination upon request by the Distribution System Inspector from initiation to completion of the project.
- f. No bore may be started or performed unless the Distribution System Inspector is present. Any water service line bored without the Distribution System Inspector present will be removed and re-bored by the Water Contractor or Plumber, at its own expense, in the Distribution System Inspector's presence. The Water Contractor or Plumber shall be responsible for all boring costs and damages caused during or as a result of the bore(s).
- g. Any cut on City street, right-of-way, or easement will require a driving plate, barricades, hazard identification beacons, and any other safety device required by Oklahoma City or Oklahoma State standards, codes, and laws. To prevent disrupting traffic longer than necessary, removal of any paving material is prohibited sooner than twenty-four (24) hours before the tap is to be made.
- h. Plumbers or Water Contractors may bore water services up to two (2") inch pipe diameter. Bores for pipes greater than two (2") inches in diameter may only be made by Water Contractors.

- i. The Director may grant exceptions to the boring requirements; however, all exceptions must be written on the permit and must be approved prior to the commencement of any boring activities.

N. Special Requirements for Bores: Bores for public water services lines one and one-half inch (1-1/2") inches in diameter and larger.

1. Bores for water service lines one and one-half inches (1-1/2") and two (2") in diameter shall not be larger than the diameter of the water service line except when encased in steel pipe.
2. Bores for water service lines three (3") inches in diameter and larger must be encased in steel encasement pipe.
3. Encasement pipe sections must be welded with continuous welds.
4. Encasement pipe extend twelve (12") inches beyond the outside of the curb line.
5. Water service line bores must be level and at the required depth under the paved surface.

O. Relocating and removing existing water services

1. Whenever a water service line is relocated or replaced it is the responsibility of the Plumber or Water Contractor to dig up existing service, shut off corporation at the main, and remove copper pipe. The Plumber or Water Contractor must also remove any water meter box and water meter tile which is abandoned. The water Contractor or Plumber must remove the water meters and deliver to the Distribution System Inspector, upon inspection of the new or replacement water service line, all water meters and City owned Water Facilities. This requirement applies to all relocated or replaced water service lines wherever situated.

P. Compliance with these Specifications.

1. These Specification shall be in addition to all applicable codes, provided in the case of a conflict between these Specifications and any code, the Water Contractor or Plumber must address the issue to the Director who shall determine the standard to be met.
2. All cost and expense for compliance with these Specifications will be borne by the Water Contractor or Plumber.

3. After inspection and approval of any water service, meter, or meter facility in the public utility or City right-of-way, public street or City easement, or on City property in compliance with these Specifications shall be deemed dedicated to and accepted as owned by the City of Oklahoma City.
4. Approval of plans require the submission of the plans meeting the requirements of these Specifications to the Water and Wastewater Utilities Department, Engineering Division prior to commencement of any excavation, construction, or installation and the signing of those plans by the Director.
5. The Director may supplement or modify these Specification from time to time upon delivery of such modifications or supplements to the City Clerk and the City Engineer for the City of Oklahoma City.
6. Any variation or deviation the Distribution System Inspector is authorized by these Specifications to grant must be approved by the Distribution System Inspector prior to installation and noted by the Inspector on the permit. It shall be the responsibility of the property owner to maintain a record of approval of any approved variation.
7. After acceptance of the water lines, water meters, and meter facilities by the City, the City shall own, operate and maintain the water line, water meter, and meter facilities from the City owned water main to the tail piece on the City owned water meter.

### **Definitions:**

“Director” means the Director of the Water and Wastewater Utilities Department of the City of Oklahoma City or the Director’s designee.

“*Distribution System Inspector*” means a Distribution System Inspector for the Utility Customer Service Division of the Water and Wastewater Utilities Department.

“*Fire hydrant*” means a public fire hydrant, which is inspected, accepted, and owned by Oklahoma City.

“*Fire hydrant lead*” means a public service line, which is inspected, accepted, and owned by Oklahoma City, connecting an public fire hydrant to a public water main.

“*Fire line*” means a six inch or larger public line, which is inspected, accepted, and owned by Oklahoma City that has been installed to and serves a fire hydrant or fire system.

“*Large water meters*” are water meters three inches (3”) and larger.

“*Meter facilities*” means those facilities connected to a meter or required in order install a meter on a water service line including but not limited to the meter pits, meter vaults, cut off valves, meter tile, meter tailpiece, and any other facility, structure or device required or approved by the Director or these Specifications.

“*New Service Supervisor*” means the person designated by the Director of the Water and Wastewater Utilities Department of the City of Oklahoma City as the Supervisor of the Distribution System Inspectors and his or her designee.

“*Non-domestic service meter*” means a meter used for non-domestic services.

“*Non-domestic services*” means any water meter that is used for a fire sprinkler system, private fire line or lead, a landscape irrigation system, cooling systems, directly services a swimming pool, or any water service line or appurtenance supplying water that could be chemically treated in-line or within the private water system.

“*Non-domestic service line*” means the private water service line or lead on the outlet (customer) side of the non-domestic service meter including the line, backflow prevention device, and other private facilities.

“*Oklahoma City water system*” means the water system owned by the City of Oklahoma City.

“*Plumber*” means any person with current State of Oklahoma and/or Oklahoma City journeyman plumber or plumbing contractor’s license and who meets the requirements of section A 1 of these Specifications.

“*Private fire hydrant*” means a private fire hydrant not accepted and not owned by Oklahoma City.

“*Private fire hydrant lead*” means a private service line connecting a private fire hydrant to a public water main.

“*Private fire line*” means a private fire line not accepted and not owned by Oklahoma City.

“*Private water system*” means any water system, facilities, or appurtenances on the outlet (customer) side of the public water meter tailpiece. The private water system is owned by a person or entity other than the Oklahoma City and the water facilities

“*Private water service line*” means the water line and any facilities or appurtenances on the outlet (customer) side of the public water meter tailpiece. The private water service line regardless of size is owned by a person or entity other than the Oklahoma City.

“*Public*” means owned by the City, dedicated or donated to and accepted by the City, or to be dedicated or donated to and accepted by the City; provided that Oklahoma City shall not own or accept any water facility that is not in a public utility or City right-of-way, public street or City easement, or on City property nor shall it own or accept any water facility that has not been constructed, installed, inspected, and dedicated in accordance with these Specifications.

“*Public property*” means any statutory right-of-way, public utility easement or right-of-way, or public street in the City of Oklahoma City, any Oklahoma City easement or right-of-way, and any Oklahoma City or Oklahoma City Water Utilities Trust property.

“*Public Water Facilities*” and “*Oklahoma City Water Facilities*” means any water facility on public property which facilities are owned by the City, and owned and accepted by the City, or to be dedicated or donated to, owned, and accepted by the City and which facilities are connected or to be connected, directly or indirectly, to the Oklahoma City water system.

“*Specifications*” means “The City of Oklahoma City Specifications for Water Meters and Water Service Installations.”

“*Water Contractor*” means any person with current status as a prequalified Water Contractor granted by the Oklahoma City Prequalification Review Board and an Oklahoma City Water Contractor’s license and who meets the requirements of Section A.1. of these Specifications.

“*Water distribution main*” means a water main or water main extension up to and including twenty inches (20”) in diameter, which is inspected, accepted, and owned by Oklahoma City.

“*Water Engineering*” means the authorized staff of the Water Engineering Division of the Water and Wastewater Utilities Department of the City of Oklahoma City.

“*Water facility*” or “*water facilities*” includes but not limited to water mains, water service lines, water meters, meter facilities, water meter tiles, water meter pits/vaults, valves, taps,

backflow prevention devices, valve, connection, corporation, curb stop, and tailpiece and associated water facility.

“*Water main*” means a water transmission main or a water distribution main, which is inspected, accepted, and owned by Oklahoma City.

“*Water service line*” means the water line and any facilities or appurtenances between the water main and the inlet (City) side of the water meter, which have been inspected, accepted, and owned by Oklahoma City. The water service line is owned by the Oklahoma City.

“*Water transmission main*” means a water main or water main extension in excess of twenty inches (20”) in diameter, which is inspected, accepted, and owned by Oklahoma City and which can not be tapped with anything smaller than a six (6) inch line or main.

U:\WATER & WASTEWATER UTILITIES\Specifications\METER SPECS Annotated 012406.doc



# STANDARD CAST IRON HEAVY DUTY METER BOX RING AND LID

WEIGHT OF RING CASTING 41 LBS.

WEIGHT OF LID CASTING 37 LBS.

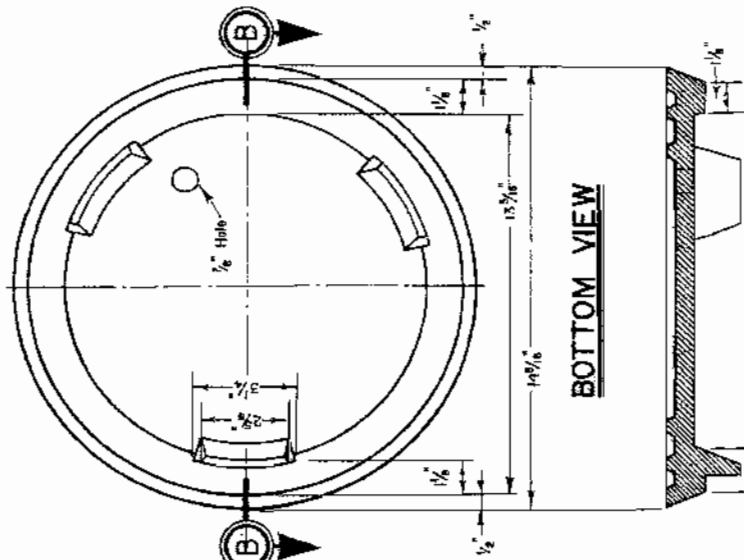
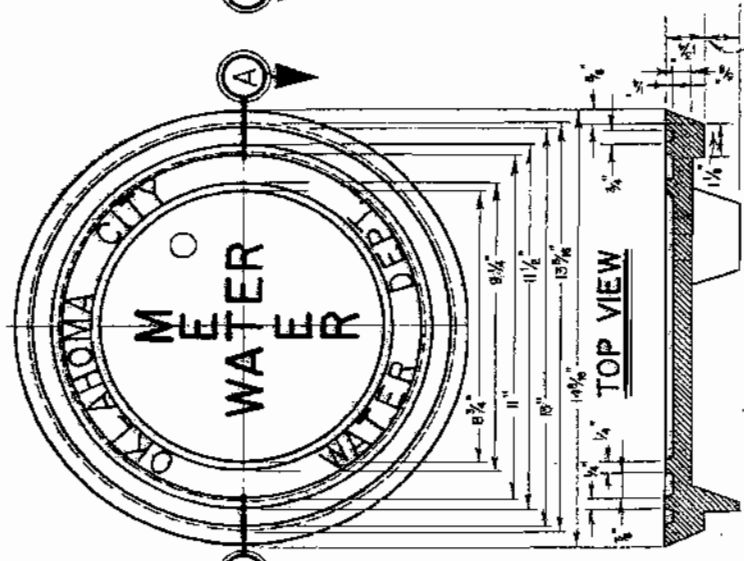
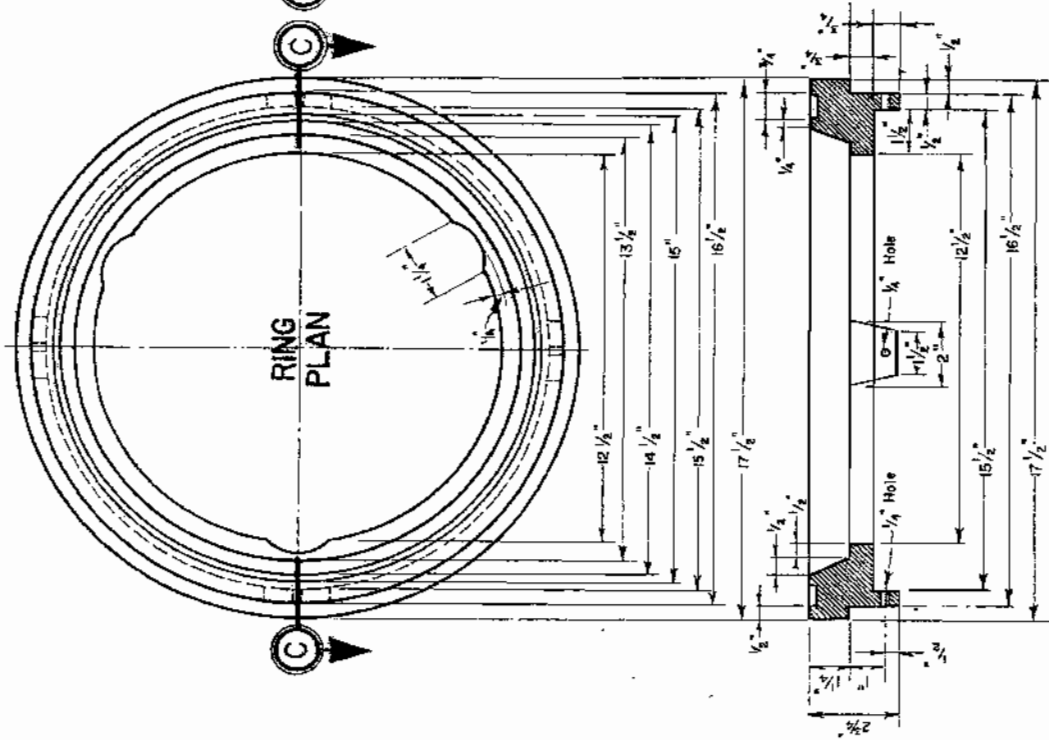

Note:  
In use in Driveways and other Locations  
where Standard Weights unsuitable.

OKLAHOMA CITY WATER DEPARTMENT  
OKLAHOMA CITY OKLAHOMA

**STANDARD CAST IRON HEAVY DUTY  
METER BOX RING AND LID**

DATE 4-5-61

APPROVED *Frank S. Taylor*  
Frank S. Taylor, Director Water Service

SCALE 3" = 1'-0"

STANDARD NO. 4



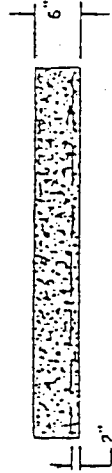
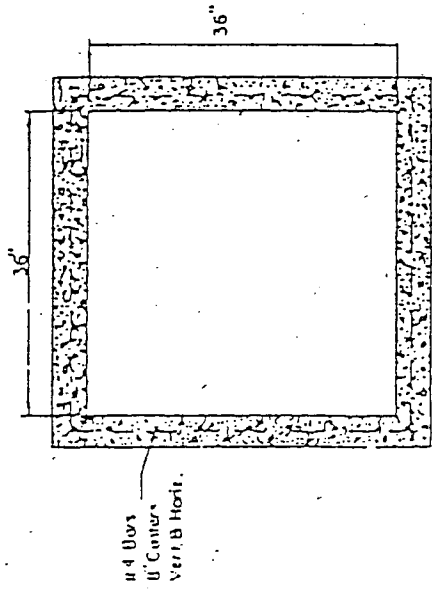
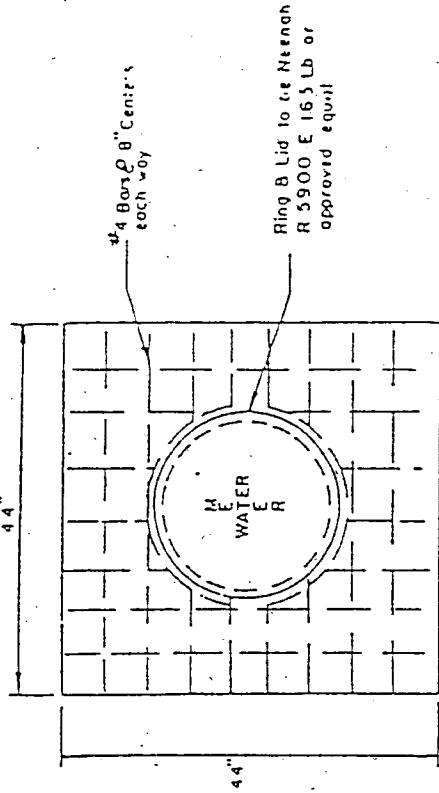

Poured in Place Pili,  
Standard No. 64

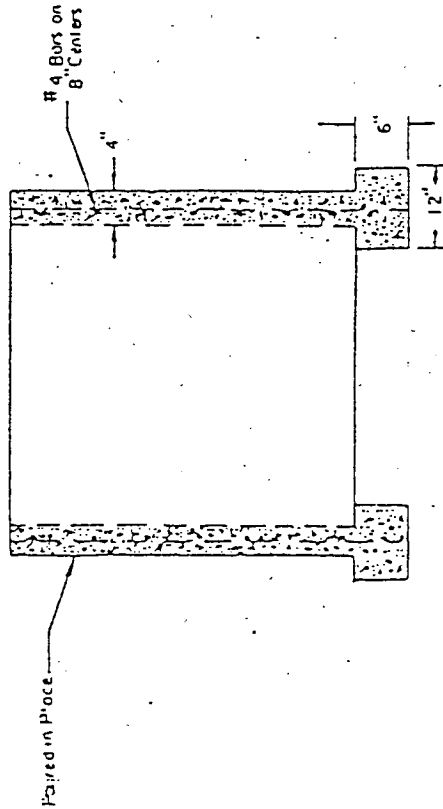

APPROVED *[Signature]* DATE 5-18-82  
MERRILL H. KELLEY, REG. PRO. ENR. 7806

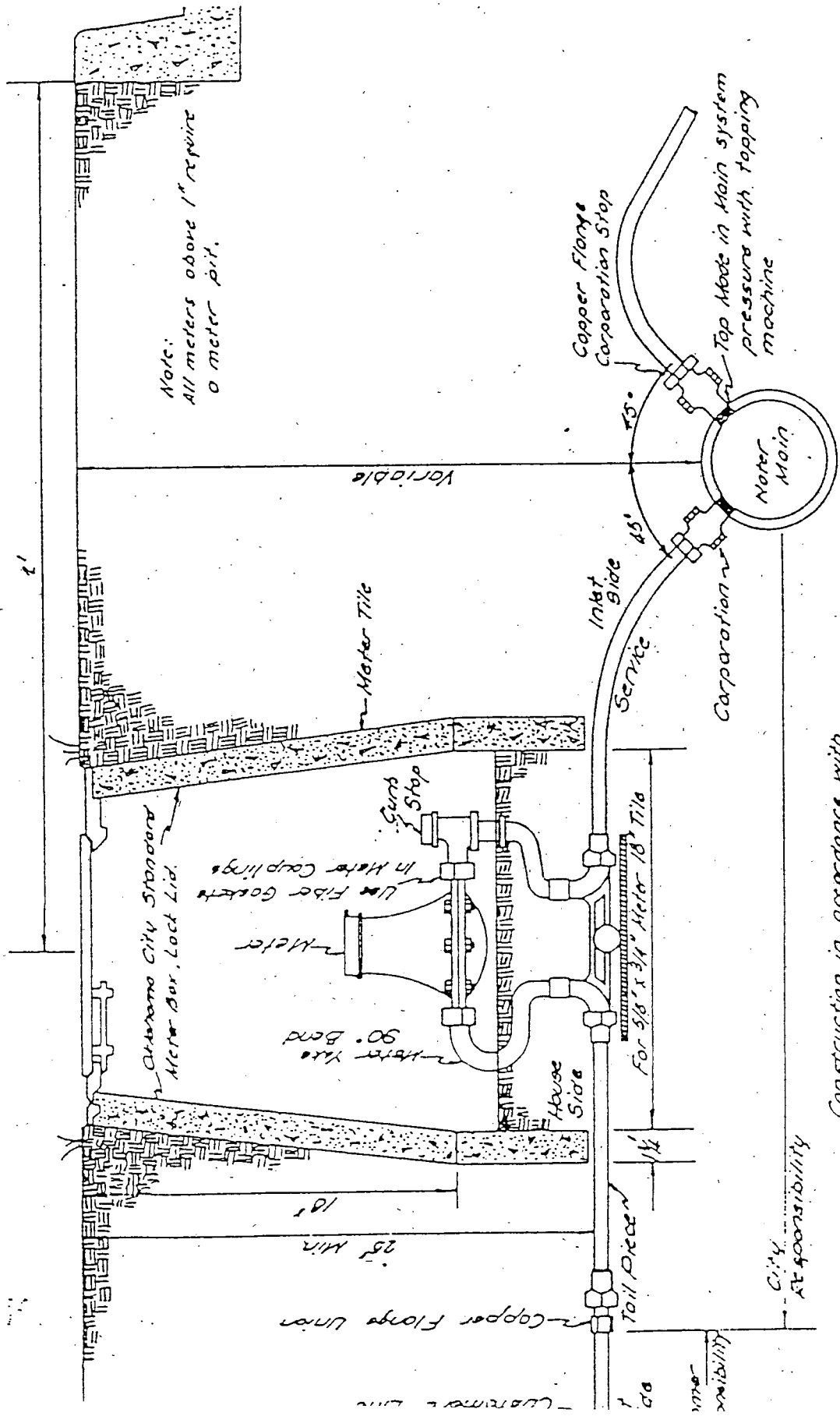

Note:  
All meters above 1" require  
a meter pit.

Construction in accordance with  
Oklahoma City Standard Specifications

City  
Responsibility

# METER PIT FOR DOMESTIC WATER SERVICE

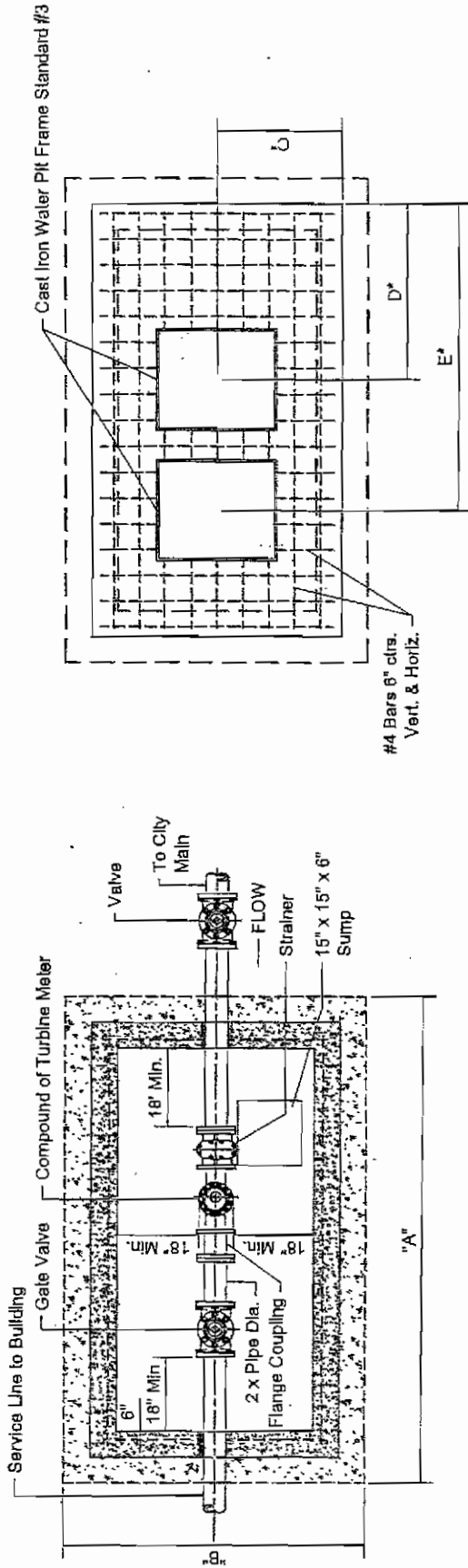

METER PIT	A	B	C*	D*	E*
3"	8' - 0"	5' - 0"	2' - 6"	3' - 2"	5' - 1"
4"	8' - 3"	5' - 0"	2' - 6"	3' - 3"	5' - 10"
6"	9' - 3"	5' - 6"	2' - 9"	3' - 9"	6' - 8"
8"	14' - 0"	6' - 0"	3' - 0"	5' - 11"	11' - 3"

Dimensions are approximate. Openings must be positioned over respective devices to they can be operated or read from outside pit.

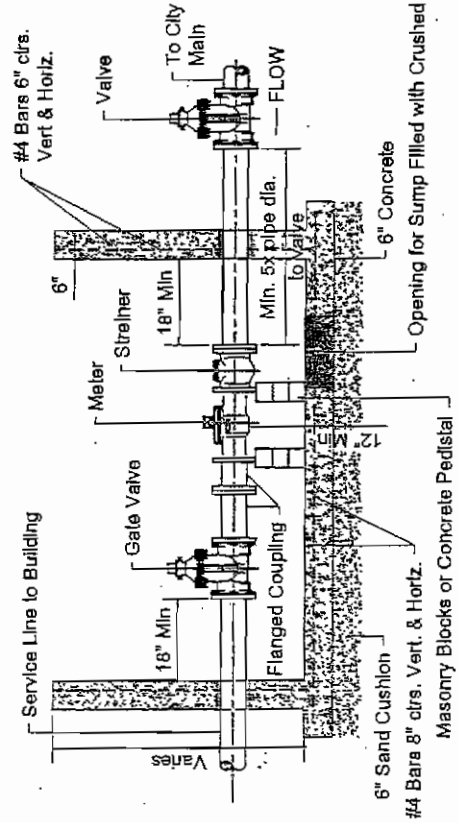

# METER PIT FOR DOMESTIC WATER SERVICE

APPROVED BY:

Paul H. Efum, P.E., City Engineer

APPROVED BY:

Marsha Slaughter, P.E., Director Water & Wastewater

H2O-Meter Pit

1 OF 1 VSC

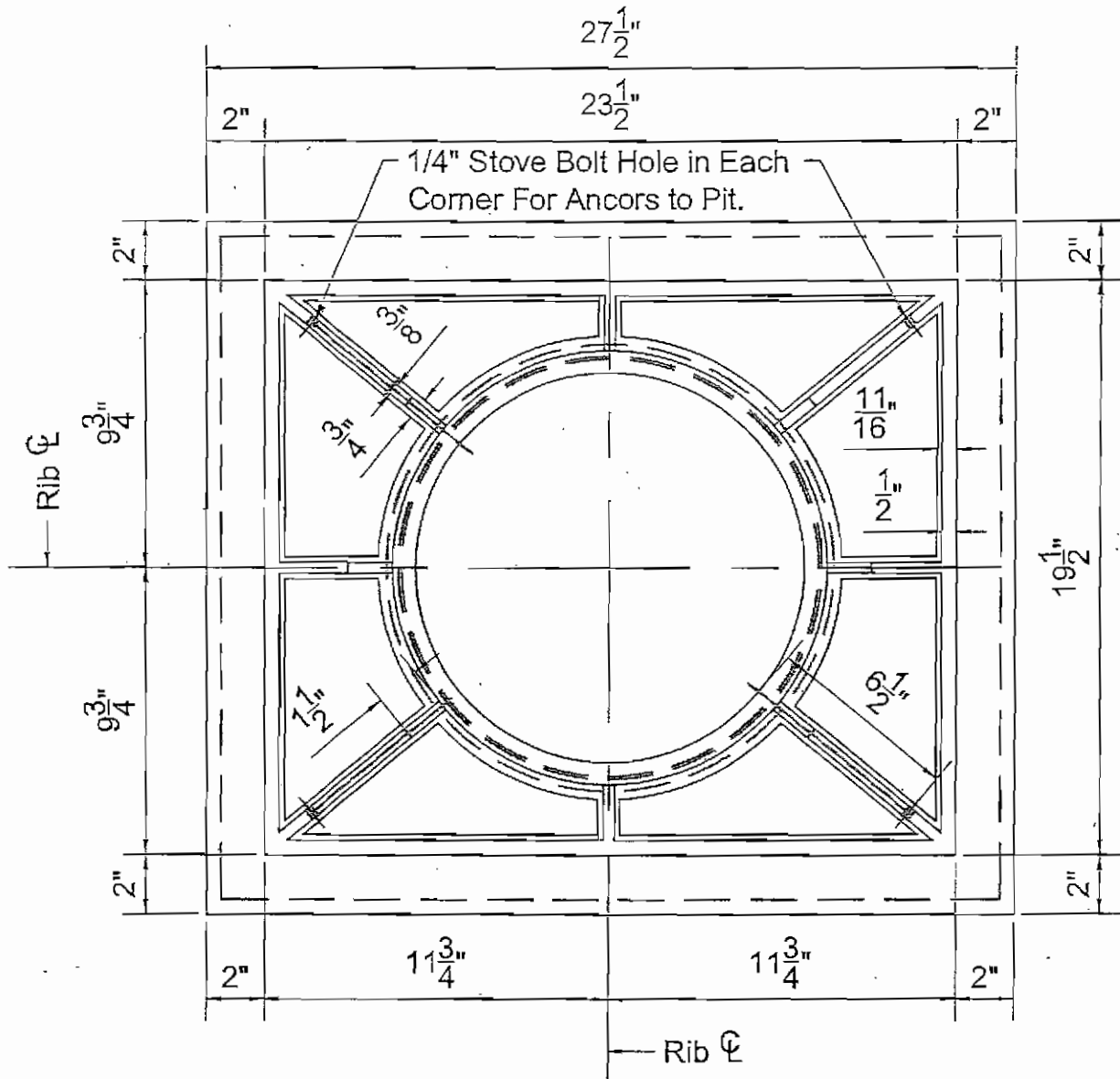

## BOTTOM ELEVATION

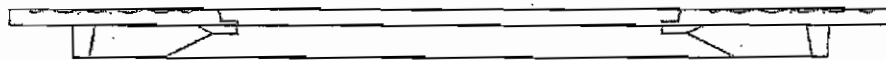

## END VIEW

### STANDARD 32 1/2" X 27 1/2" CAST IRON METER PIT FRAME

APPROVED BY:

Paul H. Brum, P.E., City Engineer

APPROVED BY:

Marsha Slaughter, P.E., Director Water & Wastewater

H2O-MPF2-A1

1 OF 2 | VSC

Note:  
 Weight of Casting 80 Lbs.  
 Scale: 2" = 1'-0"

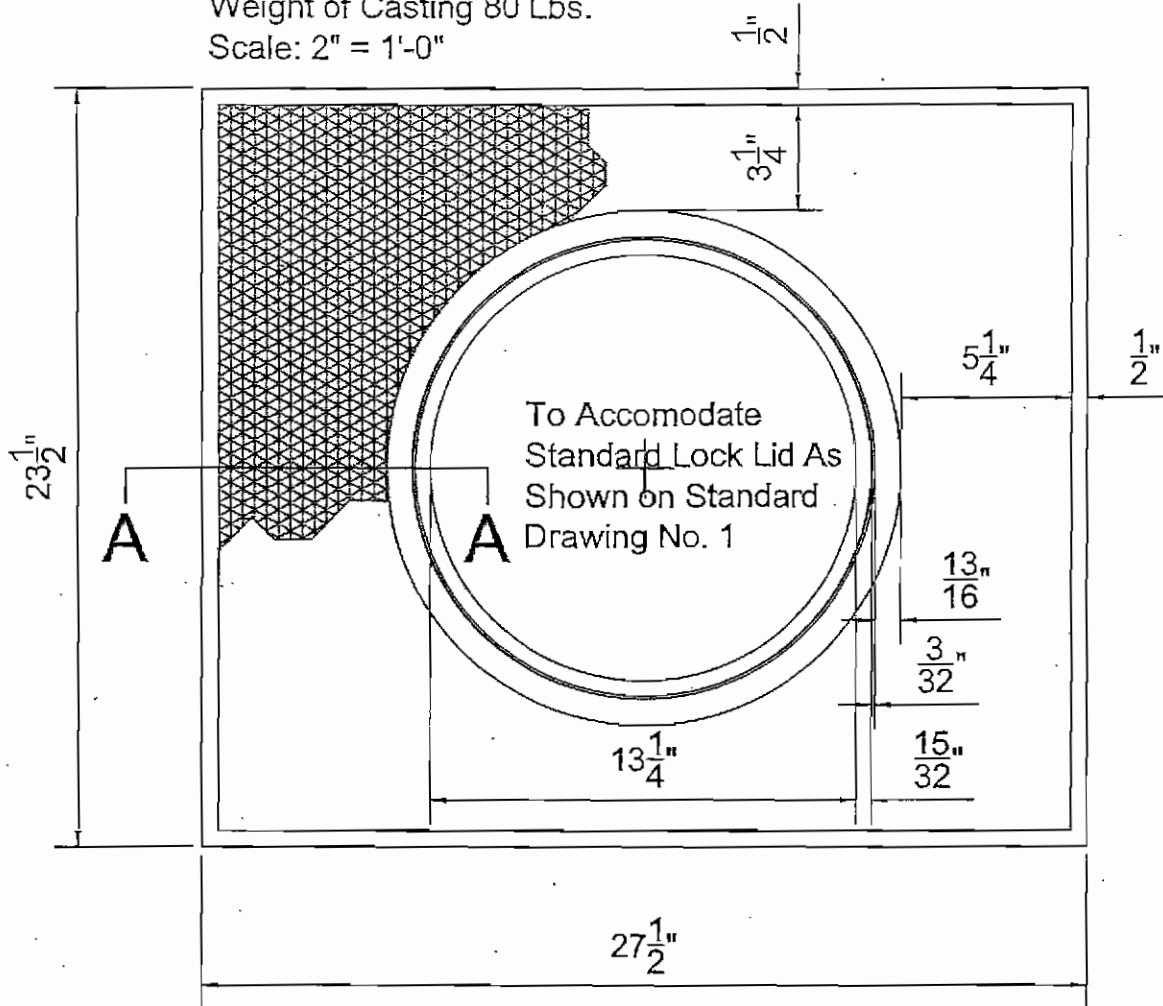

**TOP ELEVATION**

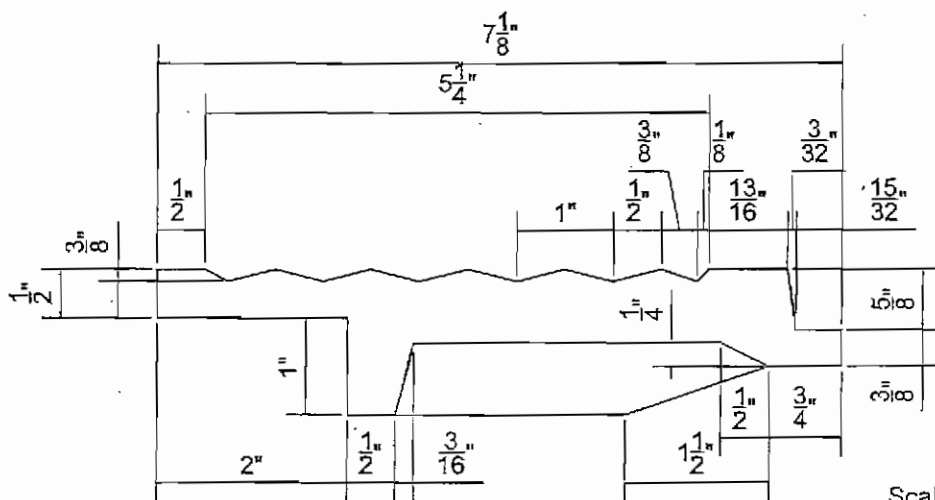

**SECTION A-A**

**STANDARD 23 1/2" X 27 1/2" CAST IRON METER PIT FRAME**

APPROVED BY:

*Paul H. Brum*  
 Paul H. Brum, P.E., City Engineer

APPROVED BY:

*Marsha Slaughter* 2/6/05  
 Marsha Slaughter, P.E., Director Water & Wastewater

H2O-MPF-A1

1 OF 2 VSC

# MSBCF-XL Series Meter Boxes

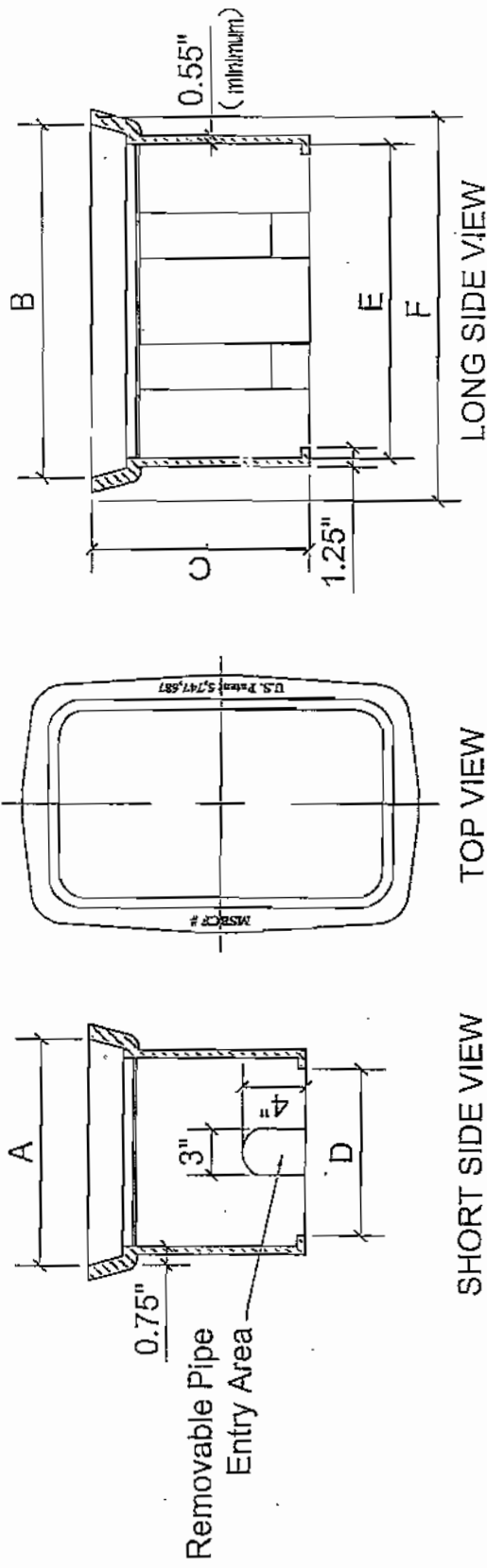

Part Number	A	B	C	D	E	F	Weight
MSBCF1015-12XL	10.5"	15.5"	12"	10"	13.5"	15.75"	13 lbs
MSBCF1118-12XL	11.25"	18.125"	12"	10.125"	17.375"	18.875"	15 lbs
MSBCF1118-18XL	11.25"	18.125"	18"	10.125"	17.375"	18.875"	19.5 lbs
MSBCF1324-12XL	13.75"	23.1875"	12"	12.125"	21.5"	23.125"	18 lbs
MSBCF1324-18XL	13.75"	23.1875"	18"	12.125"	21.5"	23.125"	22.5 lbs
MSBCF1527-18XL	15.75"	26.875"	18"	13.5"	25"	27.25"	24 lbs
MSBCF1730-18XL	17.625"	30.5"	18"	16"	28.75"	30.75"	27 lbs

\*\*All dimensions and weights are nominal and subject to changes without notice\*\*

**Typical Specifications:**

The Meter box shall be high-density Polyethylene of one-piece molded construction for durability and impact strength and shall have a wall thickness of no less than .550". The Meter box, with a ductile iron cover installed, shall be able to bear a 20,000 lb. load in a wheel load (H-20) style test. Meter box shall be able to withstand a 200 lb. side load applied with a 4"x4" plate 1" down for the top center of the box, without deflecting more than 1". The Meter box shall be black on the exterior to prevent UV degradation, and bright white on the interior to reflect light and ease meter reading and service. The box shall be designed in such a way as to have an integral flange, no more than 3" from the top, to support the box in concrete, paving or soil, and a bottom flange a minimum of 1" wide to help retard settling. The box shall have removable pre-cut pipe entry areas, 3" wide x 4" high, located on the center of each end (short side) of the box for single meter installations, and a 3 pre-cut pipe entry areas (single in, dual out) for dual meter installations. The box shall be designed in such a way as to be securely stackable, and shall be available in 12" and 18" heights as installation conditions may require. The box shall weigh no more than listed weight for each meter size for safety and ease of handling, transport and installation. All dimensions shall be in accordance with the above drawing (s) for the appropriate size meter. The meter box shall be MSBCF-XL as manufactured by Mid-States Plastics Inc. or equal.

METER BOX FOR PAVED AREAS

OKLAHOMA CITY WATER & WASTEWATER UTILITIES

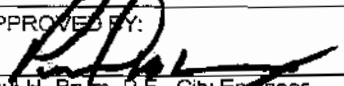
APPROVED BY:  
  
 Paul H. Brun, P.E., City Engineer

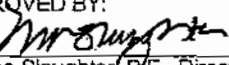
APPROVED BY:  
 7/6/05  
 Marsha Slaughter, P.E., Director Water & Wastewater

H2O-A65  
 1 OF 3 VSC



# MSBCF-XL Series Meter Boxes

3/8" LETTERING  
(RECESSED FLUSH)

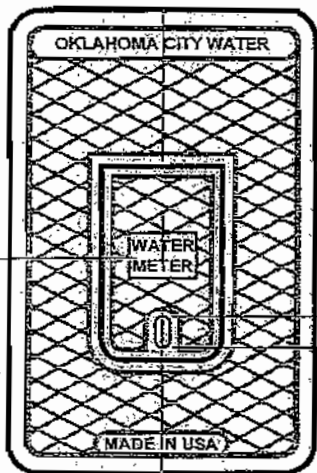

PLAN VIEW

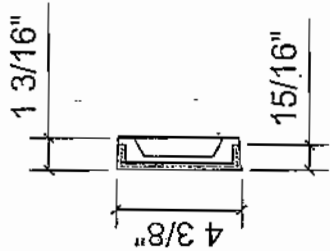

COVER SECTION

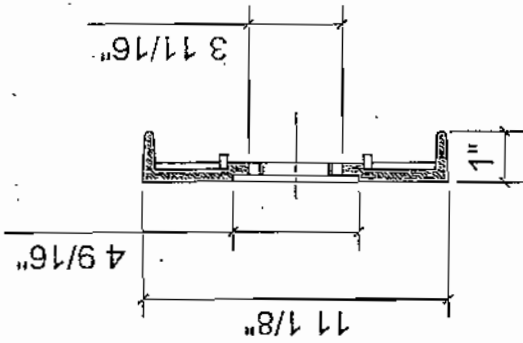

COVER SECTION

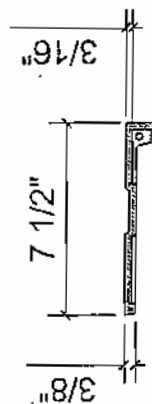

COVER SECTION

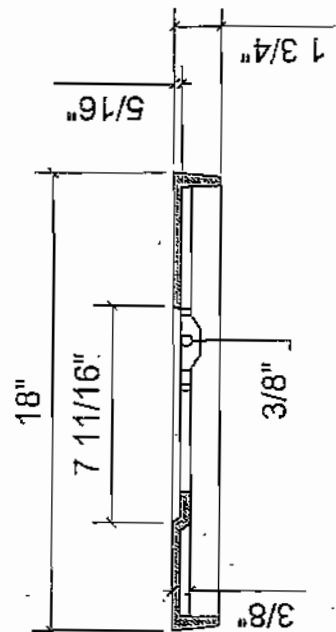

COVER SECTION

HINGE PIN  
1/4" DIA. X 7" LG.

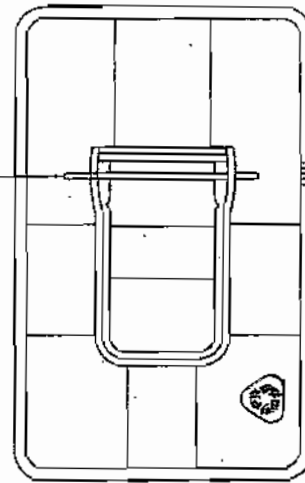

(1) SLOT TO INSTALL  
HINGE PIN TO  
INNER COVER

BOTTOM VIEW

5/8" & 1" METER BOX LID FOR PAVED AREA

OKLAHOMA CITY WATER & WASTEWATER UTILITIES

APPROVED BY:

Paul H. Brun, P.E., City Engineer

APPROVED BY:

Marsha Slaughter, P.E., Director Water & Wastewater

H2O-A65

2 OF 3

VSC

MSBCF-XL SERIES METER BOXES

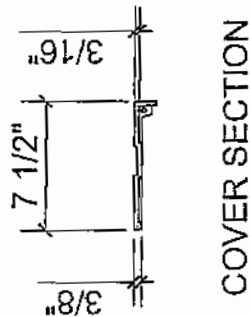
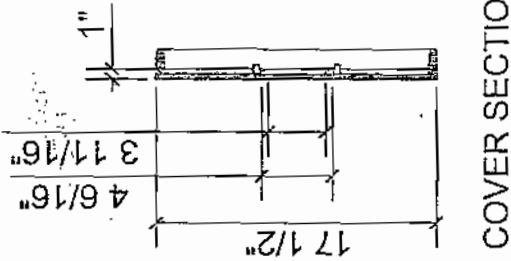
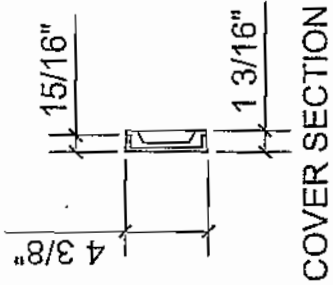
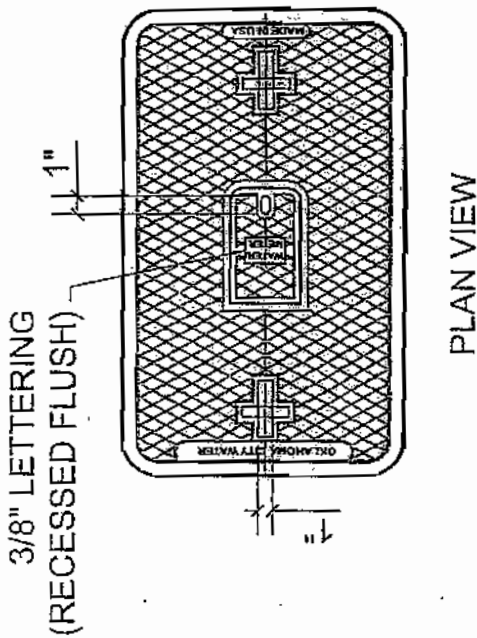

HINGE PIN  
1/4" DIA. X 7" LG.

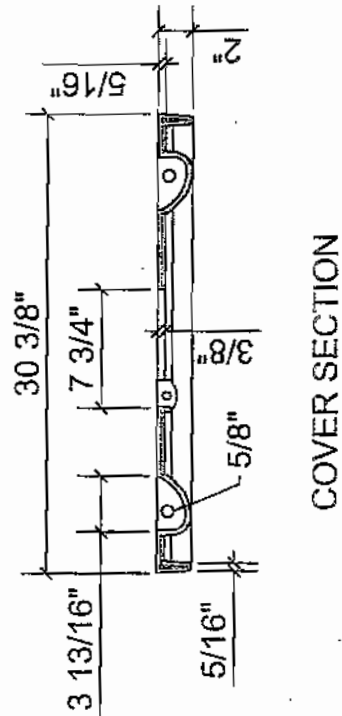
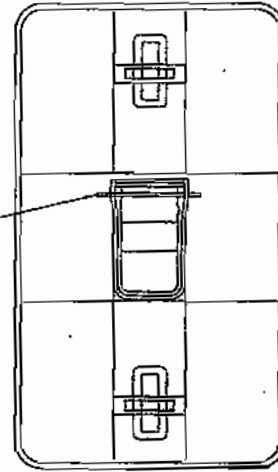

1 1/2" & 2" METER BOX LID FOR PAVED AREAS

OKLAHOMA CITY WATER & WASTEWATER UTILITIES

APPROVED BY:

Paul H. Brum, P.E., City Engineer

APPROVED BY:

Marsha Slaughter, P.E., Director Water & Wastewater

H2O-A65

3 OF 3

VSC



1160 Nicole Court  
Glendora, CA 91740  
800-735-5566 • 909-592-6272  
Fax: 909-592-7971  
www.carsonind.com

Specification Grade

**2200**

**18" Round Meter Pit**

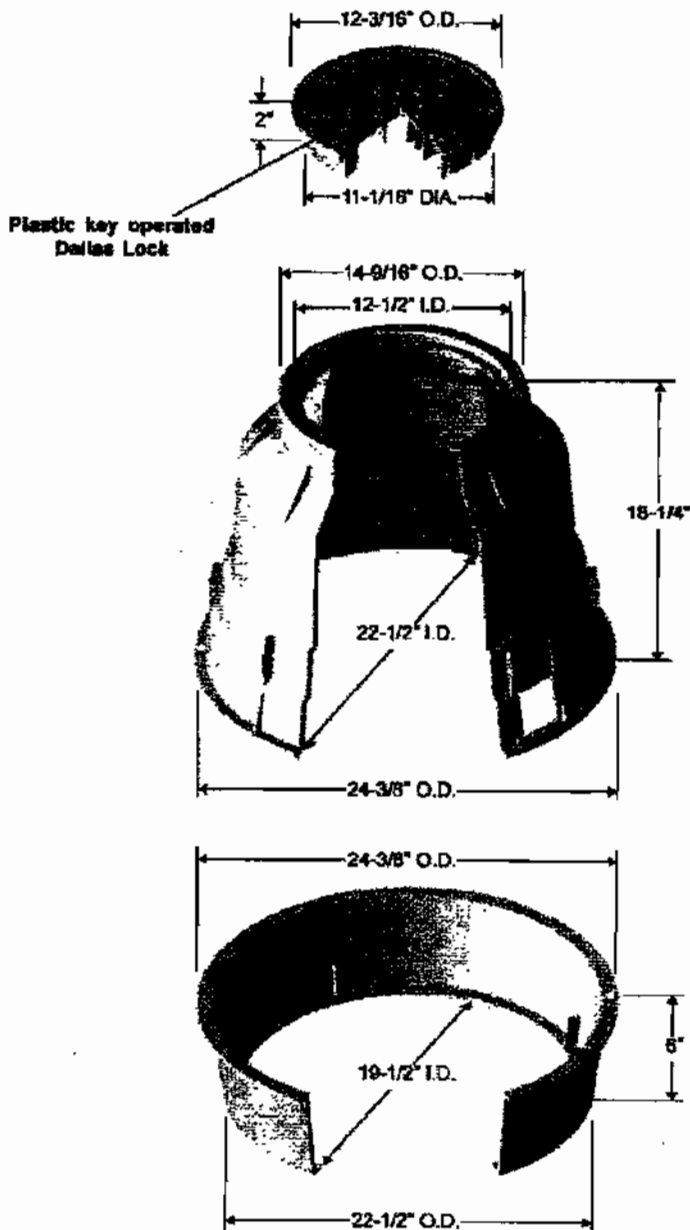

**FLUSH COVER**

Model:

- 2200-3 Plastic Cover
- 2200-3D Plastic cover with Dallas Lock
- 2200-6 Cast Iron Cover
- 2200-6D Cast Iron with Dallas Lock

**BODY**

Model:

- 2200-16

**6" BOTTOM EXTENSION**

Model:

- 2200-6X

**COLOR AVAILABLE:** Black

**Note:** For use in non-vehicular traffic situations only. We do not recommend installation in concrete or asphalt. Weights and dimensions may vary slightly.

All information contained in this brochure was current at the time of printing. Because of Carson Industries' policy of ongoing research and development, the Company reserves the right to discontinue or update product information without notice.

## Specification Grade

# 2200

## 18" Round Meter Pit

### RAW MATERIAL SPECIFICATIONS

### HDPE Structural Foam

Material Property	ASTM Test Method	Typical Value <sup>1</sup>
Type, Class, Category	D 1248	III, A, 3
Density, g/cm <sup>3</sup>	D 1505	0.950 min., not to exceed 0.965
Tensile Strength, at break, psi	D 638	3,000 to 4,400
Elongation, at break, %	D 638	400
Tensile Impact, ft-lb/in <sup>2</sup>	D 1822	27
Flexural Modulus, psi	D 790	120,000 min., not to exceed 240,000
Low Temperature Brittleness, F50, at °C	D 746	<-76
Hardness, Shore D	D 2240	86
Deflection Temperature, at 66 psi	D 648	150° min., not to exceed 200°
Electrical Dielectric Strength, V/mil	D 149	400 min., not to exceed 600

### Molded Product<sup>2</sup>

Chemical Resistance	D 543	Very Resistant
Water Absorption	D 570	Less than 1% weight change

<sup>1</sup>The values listed for physical property measurements are nominal values only. Certain physical property measurements are subject to variations consistent with the test methods and are within a generally accepted range for such values.

<sup>2</sup>Test reports available on request.

12/18/02

### SHIPPING INFORMATION

All information contained in this brochure was current at the time of printing. Because of Carson Industries' policy of ongoing research and development, the Company reserves the right to discontinue or update product information without notice.

	Weight
2200-3D Cover	4.2 lbs.
2200-18 Body	13.4 lbs.
2200-6X Extension	4.0 lbs.

### Shipping Configuration

2200-18: Unit, 64 assemblies = 138.66 cu. ft.; 1,075.0 lbs.

### Carson Industries, LLC

1160 Nicole Court  
Glendora, CA 91740  
800-735-5566 • 909-592-6272  
Fax: 909-592-7971  
www.carsonind.com